

Table of Contents

PRODUCT	PRODUCT CODE	RESOURCE DOCUMENTS	PAGE #
Variable Frequency Drives			
Introduction			F-3
Variable Frequency Drives	SED2	154-042	F-5
Variable Frequency Drives with Conventional Bypass Option	SED2	154-044	F-9
Variable Frequency Drives with Electronic (E) Bypass Options	SED2	154-051	F-15
Variable Frequency Drives NEMA Type 3R Harsh Environment Bypass	SED2	154-062	F-19
Accessories & Service Kits			F-25

Standard Shipping within 3 to 5 days Products ordered through the Rapid Response™ program can ship same day. Expect longer lead times for large quantities and unique parts. See page 2 for details on Rapid Response™ shipping.

VFD Selection Tool

Our online VFD selection tool can help you find the ideal drive. It will quickly narrow the list of over 3000 VFD options down to the one that best suits your HVAC application.

Try it today!

www.us.sbt.siemens.com/database/VFD_filter/vfd_filter.html



Variable Frequency Drives



From a global leader in drives technology comes a drive specifically configured for HVAC applications, the SED2 Variable Frequency drives from Siemens. Incorporating the latest advancements in IGBT technology, the SED2 is a PWM drive packed with standard features expected in a drive designed for HVAC variable torque applications. Unique design features make this Variable Frequency Drive (VFD) truly advanced.

Maximize energy-savings. Optimize performance.

Our HVAC products help drive down energy costs and improve indoor air quality. Look for these icons throughout this catalog for products that can help contribute to achieving LEED credits.

Sustainable Sites (SS)

Water Efficiency (WE)

Energy & Atmosphere (EA)

Materials & Resources (MR)

Indoor Environmental Quality (IEQ)

Innovation in Design/Operations (EB)

Regional Priority (RP)

Find more information on LEED beginning on pg. 3



Sustainable
Sites



Water
Efficiency



Energy &
Atmosphere



Materials &
Resources



Indoor
Environmental
Quality



Innovation in
Design/Operations

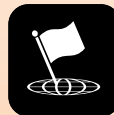

Regional
Priority

Variable Frequency Drives



Important Note:
VFD products are only available through authorized distribution channels. To locate an authorized distributor, please contact a Siemens Building Technologies representative at: **1.888.593.7876**.



Water Efficiency



Energy & Atmosphere



Indoor Environmental Quality



SED2 Variable Frequency Drives Family.

Description

The SED2 Variable Frequency Drives are designed specifically for HVAC applications. The SED2 supports a wide variety of digital and analog I/O for diverse control capability. Built-in PID features control pumps and fans, and an integral system protocol can interface P1/N2 networks. Using the SED2 multi-level parameter access, operators can quickly pinpoint relevant data.

Options

- LON Interface
- Modbus RTU Interface
- BACnet MS/TP Interface (Contact Factory)
- Advanced Operator Panel (AOP) Module
- PC Kit

Features

- Built-in SBT P1 and JCI N2 (Metasys®) building automation system protocols for easy network integration
- LON, Modbus RTU and BACnet MS/TP Interfaces optional
- Low harmonics design reduces noise and interference; eliminates need for filters/reactors in most installations
- Built-in PID for fast and accurate pressure control
- Pump staging for open loop, constant pressure, and constant flow-type applications
- Multi-level program access
- Belt failure detection with or without an external sensor
- Service mode for applications requiring continuous, uninterruptible operation
- Accepts a wide variety of digital and analog I/O types, including direct Siemens Ni 1000 RTD sensor level inputs
- One common interface throughout all power ranges
- Optional Advanced Operator Panel for uploading/downloading parameters
- Full form C relay contacts for digital outputs

F-5

Variable Frequency Drives

Variable Frequency Drives Specifications

Input Voltage and Power Ranges (3 phase)

208V and 230V to 240V, 3 ac±10%	1 hp to 60 hp
380V to 480V, 3 ac ±10%	1 hp to 125 hp
500V to 600V, 3 ac ±10%	1 hp to 125 hp
Input Frequency	47 Hz to 63 Hz
Output Frequency	0 Hz to 150 Hz
Power Factor	≥0.9
VFD degree of efficiency	96% to 97%
Switch-on Current	Less than nominal input current
Auxiliary Supply 24V	Galvanically separated, unregulated auxiliary supply (18V to 32V) 100 mA
Overload Capacity	110% for 60 seconds
Control Method	Linear, parabolic and programmable V/f; and flux current control low-power mode
PWM Frequency	2k Hz to 16k Hz (adjustable in 2k Hz increments)
Fixed Frequencies	15 programmable
Skip Frequency Bands	4 programmable
Setpoint Resolution	0.01 Hz digital 0.01 Hz serial 10 bit analog
Digital Inputs (Sink/Source)	6: fully programmable and scalable isolated digital inputs, switchable
Analog Inputs	2: 0 to 10 Vdc, 0/4 to 20 mA, can also be configured as digital inputs or Ni 1000 input

Relay Outputs	2: configurable 30 Vdc/5A (resistive), 250 Vac/2A (inductive)
Analog Outputs	2: programmable (0/4 mA to 20 mA, or 0 Vdc to 10 Vdc)
Serial Interface	RS-485 transmission rate: Up to 38.4k Baud Protocols: USS, P1 and N2
Protection Level	IP20 NEMA Type 1 with protective shield and gland plate installed IP54/NEMA Type 12
Temperature Ranges	Operating: 14°F to 104°F (-10°C to 40°C) Storage: -40°F to 158°F (-40°C to 70°C)
Humidity	95% rh, non-condensing
Operational Altitudes	Up to 3280 ft (1000m) above sea level without derating
Protection Features	Under-voltage, Over-voltage, Overload, Ground fault, Short circuit, Stall prevention, Locked motor, Motor overtemperature I ² t PTC, Over-temperature, Parameter PIN protection.
Standards	UL, cUL, CE, C-tick
CE Conformity	Conformity with EC Low Voltage Directive 73/23/EEC
Options	LON Interface, Modbus RTU Interface, BACnet MS/TP Interface, Advanced Operator Panel (AOP) Module, PC Kit

F-6

Variable Frequency Drives

Variable Frequency Drives Product Ordering

Your Product Number													
Example Product Number													
	S	E	D	2	-	0	.	7	5	/	2	2	X
Model													
SED2- VFD only													
kW rating													
0.75, 1.1, 1.5, 2.2, 3, 4, 5.5, 7.5, 11, 15, 18.5, 22, 30, 37, 45, 55, 75, 90													
(Uses 2 to 4 spaces plus a divider "/")													
[See Note 1 for these selections]													
Voltage													
2 200 to 240V													
3 380 to 480V													
4 500 to 600V													
NEMA rating													
2 (IP 20)													
1 NEMA Type 1													
5 NEMA Type 12 (IP 54) [See Note 1]													
Filter													
X Factory Required Designator													

Notes:

1. Available only with Voltage Codes 3 and 4.

Example Shown:

SED2-0.75/22X =
SED2 VFD only, 0.75 kW (1 hp), 200 to 240V, open type IP20.

Variable Frequency Drives Output Ratings

Voltage (±10%)	Product No.			Output Rating		Output Current Max (amps)	Frame Size
	IP20	NEMA Type 1	IP54/NEMA Type 12	HP	kW		
208V to 230V to 240V (3-Phase)	SED2-0.75/22X	SED2-0.75/21X	—	1.0	0.75	3.9	A
	SED2-1.1/22X	SED2-1.1/21X	—	1.5	1.1	5.5	B
	SED2-1.5/22X	SED2-1.5/21X	—	2.0	1.5	7.4	B
	SED2-2.2/22X	SED2-2.2/21X	—	3.0	2.2	10.4	B
	SED2-3/22X	SED2-3/21X	—	4.0	3.0	13.6	C
	SED2-4/22X	SED2-4/21X	—	5.0	4.0	17.5	C
	SED2-5.5/22X	SED2-5.5/21X	—	7.5	5.5	22.0	C
	SED2-7.5/22X	SED2-7.5/21X	—	10.0	7.5	28.0	C
	SED2-11/22X	SED2-11/21X	—	15.0	11.0	42.0	D
	SED2-15/22X	SED2-15/21X	—	20.0	15.0	54.0	D
	SED2-18.5/22X	SED2-18.5/21X	—	25.0	18.5	68.0	D
	SED2-22/22X	SED2-22/21X	—	30.0	22.0	80.0	E
	SED2-30/22X	SED2-30/21X	—	40.0	30.0	104.0	E
	SED2-37/22X	SED2-37/21X	—	50.0	37.0	130.0	F
SED2-45/22X	SED2-45/21X	—	60.0	45.0	154.0	F	
380V to 480V (3-Phase)	SED2-0.75/32X	SED2-0.75/31X	—	1.0	0.75	2.1	A
	SED2-1.1/32X	SED2-1.1/31X	SED2-1.1/35X	1.5	1.1	3.0	A*
	SED2-1.5/32X	SED2-1.5/31X	SED2-1.5/35X	2.0	1.5	4.0	A*
	SED2-2.2/32X	SED2-2.2/31X	SED2-2.2/35X	3.0	2.2	5.9	B
	SED2-3/32X	SED2-3/31X	SED2-3/35X	4.0	3.0	7.7	B
	SED2-4/32X	SED2-4/31X	SED2-4/35X	5.0	4.0	10.2	B
	SED2-5.5/32X	SED2-5.5/31X	SED2-5.5/35X	7.5	5.5	13.2	C
	SED2-7.5/32X	SED2-7.5/31X	SED2-7.5/35X	10.0	7.5	18.4	C
	SED2-11/32X	SED2-11/31X	SED2-11/35X	15.0	11.0	26.0	C
	SED2-15/32X	SED2-15/31X	SED2-15/35X	20.0	15.0	32.0	C
	SED2-18.5/32X	SED2-18.5/31X	SED2-18.5/35X	25.0	18.5	38.0	D
	SED2-22/32X	SED2-22/31X	SED2-22/35X	30.0	22.0	45.0	D
	SED2-30/32X	SED2-30/31X	SED2-30/35X	40.0	30.0	62.0	D
	SED2-37/32X	SED2-37/31X	SED2-37/35X	50.0	37.0	75.0	E
	SED2-45/32X	SED2-45/31X	SED2-45/35X	60.0	45.0	90.0	E
	SED2-55/32X	SED2-55/31X	SED2-55/35X	75.0	55.0	110.0	F
SED2-75/32X	SED2-75/31X	SED2-75/35X	100.0	75.0	145.0	F	
SED2-90/32X	SED2-90/31X	SED2-90/35X	125.0	90.0	178.0	F	
500V to 600V (3-Phase)	SED2-0.75/42X	SED2-0.75/41X	—	1.0	0.75	1.4	C
	SED2-1.1/42X	SED2-1.1/41X	SED2-1.1/45X	1.5	1.1	2.1	C
	SED2-1.5/42X	SED2-1.5/41X	SED2-1.5/45X	2.0	1.5	2.7	C
	SED2-2.2/42X	SED2-2.2/41X	SED2-2.2/45X	3.0	2.2	3.9	C
	SED2-3/42X	SED2-3/41X	SED2-3/45X	4.0	3.0	5.4	C
	SED2-4/42X	SED2-4/41X	SED2-4/45X	5.0	4.0	6.1	C
	SED2-5.5/42X	SED2-5.5/41X	SED2-5.5/45X	7.5	5.5	9.0	C
	SED2-7.5/42X	SED2-7.5/41X	SED2-7.5/45X	10.0	7.5	11.0	C
	SED2-11/42X	SED2-11/41X	SED2-11/45X	15.0	11.0	17.0	C
	SED2-15/42X	SED2-15/41X	SED2-15/45X	20.0	15.0	22.0	C
	SED2-18.5/42X	SED2-18.5/41X	SED2-18.5/45X	25.0	18.5	27.0	D
	SED2-22/42X	SED2-22/41X	SED2-22/45X	30.0	22.0	32.0	D
	SED2-30/42X	SED2-30/41X	SED2-30/45X	40.0	30.0	41.0	D
	SED2-37/42X	SED2-37/41X	SED2-37/45X	50.0	37.0	52.0	E
	SED2-45/42X	SED2-45/41X	SED2-45/45X	60.0	45.0	62.0	E
	SED2-55/42X	SED2-55/41X	SED2-55/45X	75.0	55.0	77.0	F
SED2-75/42X	SED2-75/41X	SED2-75/45X	100.0	75.0	99.0	F	
SED2-90/42X	SED2-90/41X	SED2-90/45X	125.0	90.0	125.0	F	

*IP54/NEMA Type 12 drives start at Frame Size B.

Variable Frequency Drives Frame Sizes

SED2 IP20 and NEMA Type 1 Frame Sizes and Power Ranges

VFD0164R1

HP	1	1.5	2	3	4	5	7.5	10	15	20	25	30	40	50	60	75	100	125
kW	.75	1.1	1.5	2.2	3	4	5.5	7.5	11	15	18.5	22	30	37	45	55	75	90
240V	A		B			C				D			E		F		N/A	
480V	A			B			C				D			E		F		
575V	C						D			E		F						

SED2 IP54 and NEMA Type 12 Frame Sizes and Power Ranges

VFD0164R1

HP	1.5	2	3	4	5	7.5	10	15	20	25	30	40	50	60	75	100	125
kW	1.1	1.5	2.2	3	4	5.5	7.5	11	15	18.5	22	30	37	45	55	75	90
480V	B				C				D			E		F			
575V	C						D			E		F					

Variable Frequency Drives Dimensions and Weights

IP20 SED2 VFDs

Frame Size	Height		Width		Depth		Weight Lb. (kg)	
A	6.8	(173)	2.9	(73)	5.9	(149)	2.9	(1.3)
B	8.0	(202)	5.9	(149)	6.8	(172)	7.5	(3.4)
C	9.6	(245)	7.3	(185)	7.7	(195)	12	(5.5)
D	20.5	(520)	10.8	(275)	9.6	(245)	35	(16)
E	25.6	(650)	10.8	(275)	9.6	(245)	44	(20)
F	33.5	(850)	13	(350)	12.6	(320)	116	(53)

NEMA Type 1 SED2 VFDs Assembled with Protective Shield and Gland Plate

Frame Size	Height		Width		Depth		Weight Lb. (kg)	
A	9.1	(231)	2.9	(73)	5.9	(149)	3.2	(1.5)
B	11.8	(300)	5.9	(149)	6.8	(172)	8.3	(3.8)
C	13.8	(351)	7.3	(185)	7.7	(195)	13.6	(6.2)
D	24.6	(625)	10.8	(275)	9.6	(245)	37.5	(17)
E	29.7	(754)	10.8	(275)	9.6	(245)	46.4	(21)
F	54.5	(1384)	16.0	(406)	14.0	(356)	200	(91)

IP54/NEMA Type 12 SED2 VFDs

Frame Size	Height		Width		Depth		Weight Lb. (kg)	
B	15.2	(385)	10.6	(270)	10.6	(268)	10	(22)
C	23.9	(606)	13.8	(350)	11.2	(284)	42	(19)
D	27.0	(685)	14.2	(360)	13.9	(353)	77	(35)
E	34.8	(885)	14.2	(360)	17.8	(453)	105	(48)
F	45.3	(1150)	17.7	(450)	18.6	(473)	178	(81)

Tables expressed in inches (mm).

Variable Frequency Drives with Conventional Bypass Options



SED2 Variable Frequency Drives with Conventional Bypass Options Family.



Important Note:
VFD products are only available through authorized distribution channels. To locate an authorized distributor, please contact a Siemens Building Technologies representative at: **1.888.593.7876**.



Water Efficiency



Energy & Atmosphere



Indoor Environmental Quality

Description

The Bypass Options are companion packages for the family of SED2 Variable Frequency Drives.

Features

Bypass Power

3-Contactor: Input, Output, & Bypass

- Overload protection in bypass mode
- Step-down transformer with fused primary and secondary
- Contactors electrically and mechanically interlocked
- Drive test function
- Complete electrical isolation of drive

Input Device

- Fused disconnect
- Circuit breaker (optional)
- All doors are interlocked and padlockable

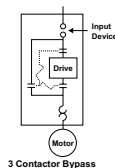

3 Contactor Bypass

Reactor Options

- Input line reactor mounted in bypass option enclosure.
- Line reactor supplied separately.
- Load reactor (in NEMA 1/3R enclosure) supplied separately.

Bypass Control

Enable Input

- Generally used for safety tie-ins; the motor will not operate the drive or bypass when open.

Common Remote Start/Stop

- Common remote start/stop can be used in both drive and bypass mode.

Essential Services Mode

- Typically used for smoke purge; the motor goes to bypass regardless of the selected mode.
- No call to stop will have an effect, including open safety or stop commands.
- Only turning the power off or opening this contact will stop the motor.

Bypass – Door Mounted Control Devices

- Drive-Off-Bypass selector
- Bypass pilot light
- Drive Test on/off selector

Variable Frequency Drives with Conventional Bypass Option Specifications

Conventional Bypass Specifications

Input Voltage (3-phase)

208V, 3 AC±10%	1 hp to 60 hp (2.3 amps to 154 amps)
240V, 3 AC±10%	1 hp to 60 hp (2.3 amps to 154 amps)
480V, 3 AC ±10%	1 hp to 125 hp (1.2 amps to 178 amps)
575V, 3 AC ±10%	1 hp to 125 hp (2.3 amps to 125 amps)

Protection Level.....NEMA Type 1
NEMA Type 12

Temperature

Operating.....	32 to 104°F (0 to +40°C)
Storage.....	-40 to +158°F (-40 to +70°C)

Humidity0 to 95% RH, non-condensing

Drive Specifications

Input Voltage and Power Ranges (3-Phase)

208V and 230V to 240V, 3AC ±10%	1 hp to 60 hp
380V to 480V, 3 AC ±10%	1 hp to 125 hp
500V to 600V, 3 AC ±10%	1 hp to 125 hp

Input Frequency.....47 Hz to 63 Hz

Output Frequency.....0 Hz to 150 Hz

Power Factor.....≥ 0.9 total, ≥ 0.97 displacement

VFD Degree of Efficiency.....96% to 97%

Switch-on Current Less than nominal input current

Auxiliary Supply 24V..... Galvanically separated, unregulated auxiliary supply (18V to 32V) 100 mA

Overload Capacity..... 110% for 60 seconds

Control Method.....Linear, parabolic and programmable V/f; and flux current control low-power mode

PWM Frequency.....2k Hz to 16k Hz (adjustable in 2k Hz increments)

Fixed Frequencies..... 15 programmable

Skip Frequency Bands..... 4 programmable

Setpoint Resolution..... 0.01 Hz digital, 0.01 Hz serial, 10 bit analog

Digital Inputs (Sink/Source).....6: fully programmable and scalable isolated digital inputs, switchable

Analog Inputs.....2: 0 to 10 Vdc, 0/4 to 20 mA, can also be configured as digital inputs or Ni 1000 input

Relay Outputs2: configurable 30 Vdc /5A (resistive), 250 Vac 2A (inductive)

Analog Outputs..... 2: programmable (0/4 to 20 mA or 0 Vdc to 10 Vdc)

Serial Interface..... RS-485;
Protocols: USS, P1 and N2;
Transmission rate: Up to 38.4k Baud

Temperature Ranges

Operating	14°F to 104°F (-10°C to 40°C)
Storage	-40°F to 158°F (-40°C to 70°C)

Humidity95% rh, non-condensing

Operational AltitudesUp to 3280 ft (1000m) above sea level without derating

Protection Features.....Under-voltage, Over-voltage, Overload, Ground fault, Short circuit, Stall prevention, Locked motor, Motor over-temperature I2 t PTC, Over-temperature, Parameter PIN protection.

Standards..... UL, cUL, CE, C-tick

CE ConformityConformity with EC Low Voltage Directive 73/23/EEC

Options..... LON Interface, Modbus Interface, BACnet MS/TP Interface (Contact Factory), Advanced Operator Panel (AOP) Module, PC Kit

F-10

Variable Frequency Drives

Variable Frequency Drives with Conventional Bypass Option Product Ordering

Your Product Number													
Example Product Number		V	B	A	3	4	0	.	B	1	3	3	X
Model	VB	VFD with Bypass											
Series	A	Conventional Bypass											
Voltage	1	208 V											
	2	230 to 240 V											
	3	380 to 480 V											
	4	500 to 600 V											
HP rating		1.0, 1.5, 2.0, 3.0, 4.0, 5.0, 7.5, 10, 15, 20, 25, 30, 40, 50, 60, 75, 100, 125 [See Note 1 for these selections]											
Disconnect	F	Fused Disconnect											
	B	Circuit Breaker											
NEMA rating	1	NEMA Type 1											
	5	NEMA Type 12 (IP 54) [See Note 2]											
Contactor	3	3 Contactors											
Reactor		[See Note 3]											
	0	None											
	3	Line Reactor											
Filter	X	Factory Required Designator											

Notes:

1. Available only with Voltage Codes 3 and 4.
2. Available only with Voltage Code 3.
3. Input line reactors will be installed in bypass enclosures. Load reactors are supplied separately in NEMA 1 or NEMA 3R enclosures.

Example shown:

VBA340.B133X

VBA Conventional Bypass, 40 HP, 480V, Circuit Breaker, NEMA Type 1, 3-Contactor Bypass with Input Line Reactor.

NEMA 1 Dimensions

NEMA 1 Conventional Bypass Approximate Weights

Frame Size	Wt. Lb (kg)
A	45 (20)
B	55 (25)
C	75 (34)
D	150 (68)
E	180 (82)
F	470 (213)

Note: Exact weight will be affected by the actual horsepower/voltage and the selected power options.

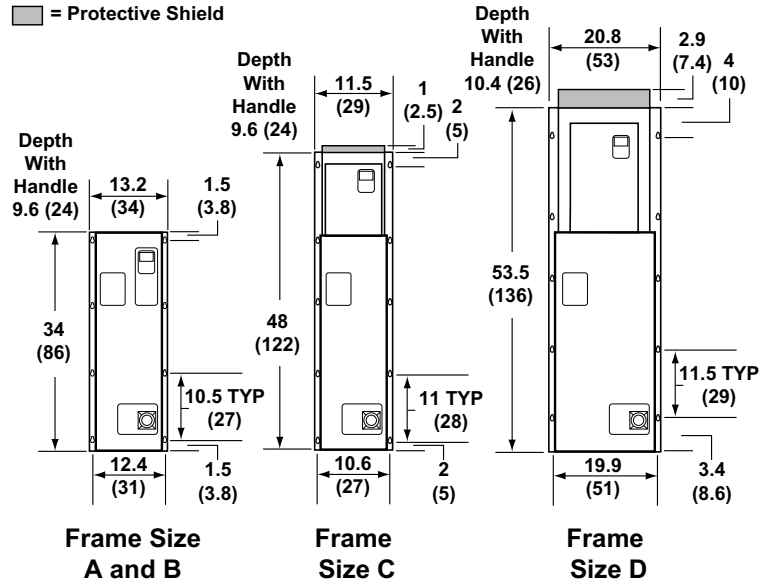

F-12

NEMA 1 Conventional Bypass Frame Sizes and Power Ranges

HP	kW	208/240V	480V	575V
1	.75	A		
1.5	1.1	B	A	
2	1.5	B		
3	2.2		B	
5	4	C		C
7.5	5.5	C		
10	7.5		C	
15	11	D		
20	15	D		
25	18.5		D	D
30	22	E	D	D
40	30	F		
50	37	F	E	E
60	45		E	
75	55		F	F
100	75	N/A	F	F
125	90			
HA1	—			N/A

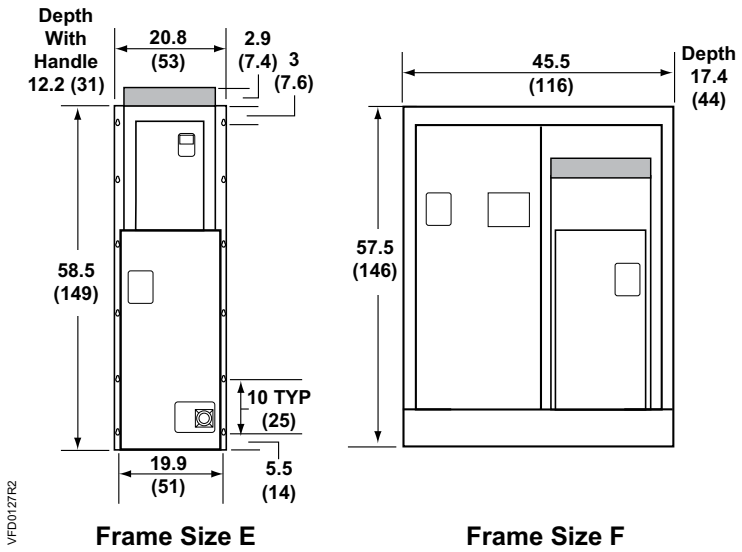

Dimensions shown in inches (mm).

Variable Frequency Drives

NEMA 12 Dimensions

NEMA 12 Conventional Bypass Approximate Weights

Frame Size	Wt. Lb. (kg)
B	100 (45)
C	130 (59)
D	185 (84)
E	225 (102)
F	350 (159)

Note: Exact weight will be affected by the actual horsepower/voltage and the selected power options.

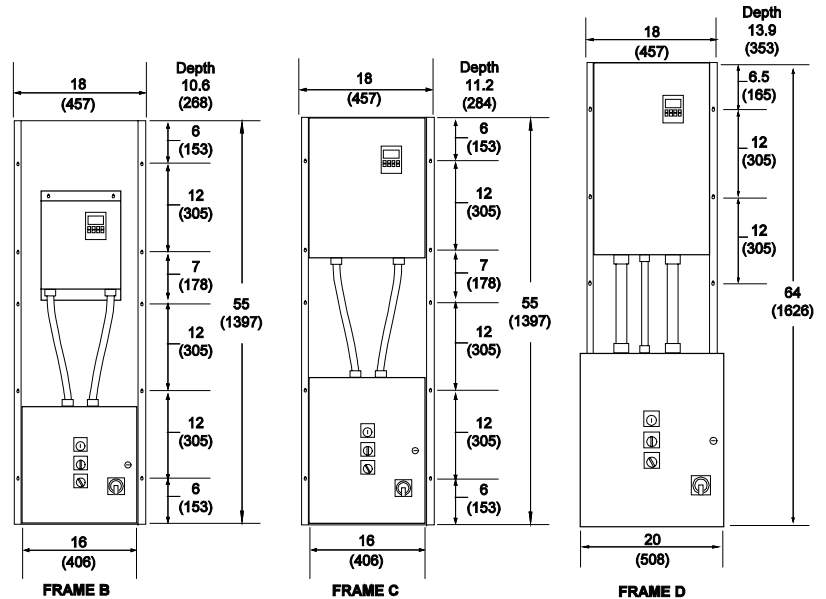

NEMA 12 Conventional Bypass Frame Sizes and Power Ranges

HP	kW	480V	575V
1.5	1.1	B & C	B & C
2	1.5		
3	2.2		
5	4		
7.5	5.5		
10	7.5		
15	11	D & E	D & E
20	15		
25	18.5		
30	22		
40	30		
50	37		
60	45	F	F
75	55		
100	75		
125	90		

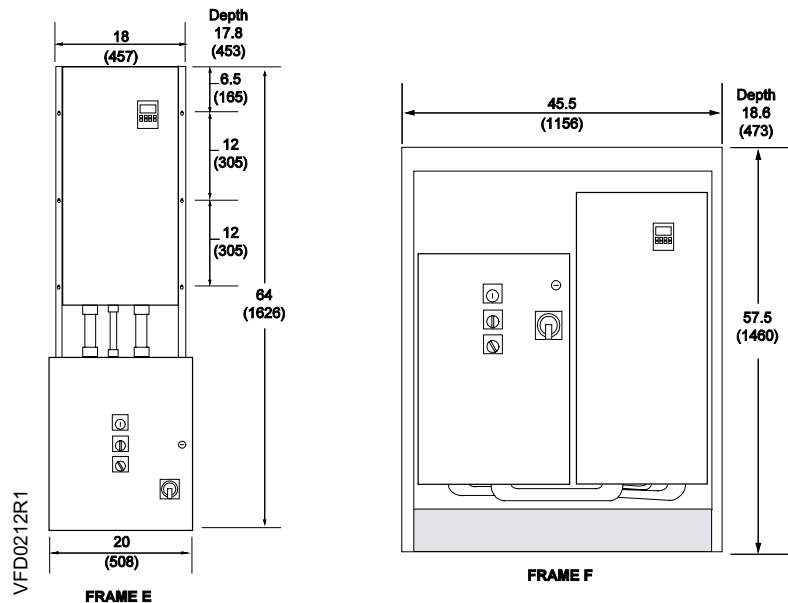

Dimensions shown in inches (mm).

NOTE: Exact weight will be affected by actual horsepower/voltage and selected power options.

Reduced harmonic distortion, reduced costs.

The SED2 VFD uses a unique low harmonic design that eliminates the need for DC link chokes and line reactors. This low harmonic design reduces noises and interference, eliminating the need for filters or reactors in most installations. The result is reduced expenses and the ability to use a smaller designed drive.



Variable Frequency Drives Electronic Bypass (E-Bypass) Options



Important Note:
VFD products are only available through authorized distribution channels. To locate an authorized distributor, please contact a Siemens Building Technologies representative at: **1.888.593.7876**.



SED2 Variable Frequency Drives with Electronic Bypass Family.



Water Efficiency



Energy & Atmosphere



Indoor Environmental Quality

Description

The SED2 Electronic Bypass (E-Bypass) Options are companion packages for the family of SED2 Variable Frequency Drives (VFDs).

Features

- Enhanced visual interface for improved monitoring and diagnostics
- E- Bypass guarantees continuous operation even if SED2 fails
- Electronic touch-sensitive keypad
- Standard built-in networking compatibility
- Service mode isolates drive from the control scheme
- Six relay outputs for indication of operation
- Fourteen LEDs indicate monitoring and operation
- Six digital inputs
- Remote start via networking
- Contactors electrically and mechanically interlocked.

E-Bypass Power

3-Contactor: Input, Output, & Bypass

- Drive test function
- Complete electrical isolation of drive
- Overload protection in bypass mode

Input Device

- Fused disconnect
- Circuit breaker (optional)
- All doors are interlocked and padlockable

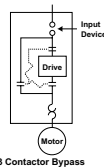

Reactor Options

- Line reactor mounted in bypass option enclosure
- Line reactor (in NEMA 1 enclosure) supplied separately
- Load reactor supplied separately

E-Bypass Control

Auto Bypass

- Relay logic allows user to send the motor to bypass mode based on the drive's programmable relay.
- The drive's programmable relay, typically set to fault, can be set up for applications that run full speed for an extended period of time.

Enable Input

- Generally used for safety tie-ins; the motor will not operate the drive or bypass when open.

Common Remote Start/Stop

- Common remote start/stop can be used in both drive and bypass mode.

Essential Services Mode

- Also used for smoke purge; the motor goes to bypass regardless of the selected mode.
- No call to stop will have an effect, including open safety or stop commands.
- Only turning the power off or opening this contact will stop the motor.

Variable Frequency Drives E-Bypass Options Specifications

Electronic Bypass Specifications

Input Voltage (3-phase)

208V, 3 AC±10%	1 hp to 60 hp (2.3 amps to 154 amps)
240V, 3 AC±10%	1 hp to 60 hp (2.3 amps to 154 amps)
480V, 3 AC ±10%	1 hp to 125 hp (1.2 amps to 178 amps)
575V, 3 AC ±10%	1 hp to 125 hp (2.3 amps to 125 amps)

Protection Level.....NEMA Type 1

Digital Inputs

Six Digital Inputs as follows..... Remote start input, Remote safety 1, Remote safety 2, Interlock start, Essential services, Overload trigger.
Inputs require a contact closure capable of providing a low impedance path at currents less than 20 mA.

Relay/Digital Outputs

Six Relay/Digital Outputs as follows.....VFD fault, Programmable output, Drive select, Bypass select, Running on bypass, Overload fault, Each relay has a maximum rating of 2A at 120Vac.

Temperature

Operating	14°F to 104°F (-10°C to 40°C)
Storage	-40°F to 158°F (-40°C to 70°C)

Humidity0 to 95% rh, non-condensing

Drive Specifications

Input Voltage and Power Ranges (3 phase), amps

208V and 230V to 240V, 3 ac ± 10%	1 hp to 60 hp (2.3 amps to 154 amps)
380V to 480V, 3 ac ± 10%	1 hp to 125 hp (1.2 amps to 178 amps)
500V to 600V, 3 ac ± 10%	1 hp to 125 hp (2.3 amps to 125 amps)

Input Frequency.....47 Hz to 63 Hz

Output Frequency.....0 Hz to 150 Hz

Power Factor.....≥ 0.9

VFD Degree of Efficiency.....96% to 97%

Switch-on Current	Less than nominal input current
Auxiliary Supply 24V	Galvanically separated, unregulated auxiliary supply (18V to 32V) 100 mA
Overload Capacity	110% for 60 seconds
Control Method	Linear, parabolic and programmable V/f; and flux current control low-power mode
PWM Frequency	2k Hz to 16k Hz (adjustable in 2k Hz increments)
Fixed Frequencies	15 programmable
Skip Frequency Bands	4 programmable
Setpoint Resolution	0.01 Hz digital 0.01 Hz serial 10 bit analog
Digital Inputs (sink/source)	6: fully programmable and scalable isolated digital inputs, switchable
Analog Inputs	2: 0 to 10 Vdc, 0/4 to 20 mA, can also be configured as digital inputs or Ni 1000 input
Relay Outputs	2: configurable 30 Vdc/5A (resistive), 250 Vac/2A (inductive)
Analog Outputs	2: programmable (0/4 mA to 20 mA or 0 Vdc to 10 Vdc)
Serial Interface	RS-485 transmission rate: Up to 38.4k Baud Protocols: Siemens Building Technologies, Inc., P1 and Johnson, N2

Temperature Ranges

Operating	14°F to 104°F (-10°C to 40°C)
Storage	-40°F to 158°F (-40°C to 70°C)

Humidity95% rh, non-condensing

Operational AltitudesUp to 3280 ft (1000 m) above sea level without derating

Protection Features..... Under-voltage, Over-voltage, Overload, Ground fault, Short circuit, Stall prevention, Locked motor, Motor over-temperature I²t PTC, Over-temperature, Parameter PIN protection.

Standards

F-16

Variable Frequency Drives

E-Bypass — Door Mounted Control Devices

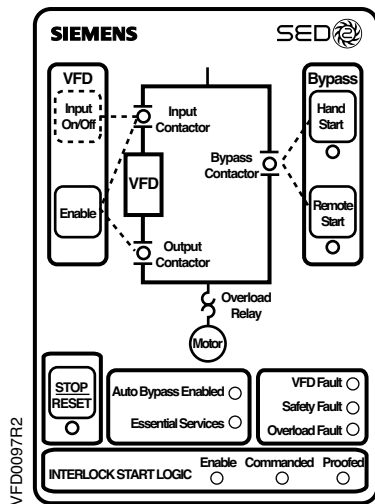

Variable Frequency Drives E-Bypass Options Options Product Ordering

Your Product Number														
Example Product Number		V	B	E	3	4	0	.	F	1	3	0	X	
Model	VB	VFD with Bypass												
Series	E	Electronic Bypass												
Voltage	1	208 V												
	2	230 to 240 V												
	3	380 to 480 V												
	4	500 to 600 V												
HP rating		1.0, 1.5, 2.0, 3.0, 4.0, 5.0, 7.5, 10, 15, 20, 25, 30, 40, 50, 60, 75, 100, 125 [See Note 1 for these selections]												
Disconnect	F	Fused Disconnect												
	B	Circuit Breaker												
NEMA rating	1	NEMA Type 1												
Contactors	3	3 Contactors												
Reactor		[See Note 2]												
	0	None												
	3	Line Reactor												
Filter	X	Factory Required Designator												

Notes:

1. Available only with Voltage Codes 3 and 4.
2. Input line reactors will be installed in bypass enclosures. Load reactors are supplied separately in NEMA 1 or NEMA 3R enclosures.

Example Shown:

VBE340.F130X

VBE Electronic Bypass, 40 hp, 480V, fused disconnect, NEMA Type 1, 3 contactors bypass, no reactor.

Variable Frequency Drives E-Bypass Dimensions

E-Bypass Approximate Weights

Frame Size	Wt. Lb (kg)
A	45 (20)
B	55 (25)
C	75 (34)
D	150 (68)
E	180 (82)
F	470 (213)

Note: Exact weight will be affected by the actual horsepower/voltage and the selected power options.

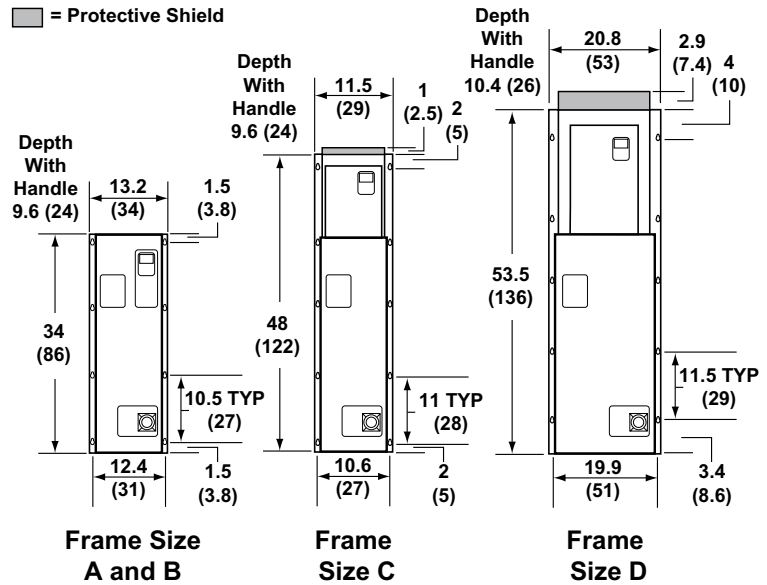

F-18

E-Bypass Frame Sizes and Power Ranges

HP	kW	208/240V	480V	575V
1	.75	A		
1.5	1.1	B	A	
2	1.5	B		
3	2.2		B	
5	4	C		C
7.5	5.5	C		
10	7.5		C	
15	11	D		
20	15	D		
25	18.5		D	D
30	22	E	D	D
40	30	F		
50	37	F	E	E
60	45		E	E
75	55		F	
100	75	N/A	F	F
125	90			
HA1	—			N/A

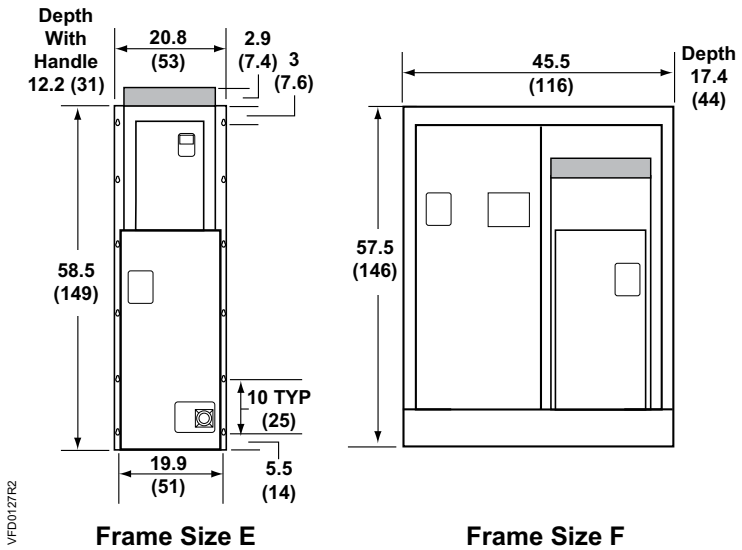

Dimensions shown in inches (mm).

Variable Frequency Drives

VFD NEMA Type 3R & Type 3R Harsh Environment (3RHE) Bypass



Important Note:

VFD products are only available through authorized distribution channels. To locate an authorized distributor, please contact a Siemens Building Technologies representative at: **1.888.593.7876**.



SED2 Variable Frequency Drives
NEMA Type 3R Bypass.



Water
Efficiency



Energy &
Atmosphere



Indoor
Environmental
Quality

Description

The NEMA Type 3R Bypasses are companion packages for the family of SED2 Variable Frequency Drives (VFD). NEMA Type 3R/3RHE enclosed bypasses are manufactured for outdoor locations that are not in direct sunlight.

Two primary styles of 3R cabinets are provided. The standard 3R rating provides protection from falling rain to the enclosed SED2 VFD and electrical control components. The harsh environment 3R rating is identical to the standard, but it is supplied with a more robust NEMA 12 SED2 VFD.

A heater is supplied in the Type 3R models to protect against condensation. The standard package is rated to 104°F (40°C). A high temperature package, rated to 122°F (50°C), is also available.

Features

Bypass Power

3-Contactor: Input, Output, and Bypass

- Overload protection in bypass mode.
- Step-down transformer with fused primary and secondary.
- Contactors electrically and mechanically interlocked.
- Drive test function.
- Complete electrical isolation of drive.

Input Device

- Fused disconnect.
- All doors are interlocked and padlockable.

Reactor Options

- Line reactor mounted in bypass enclosure.
- Line reactor supplied separately (in NEMA Type 3R enclosure).
- Load reactor supplied separately.

Bypass Control

Auto Bypass

- Relay logic allows user to send the motor to bypass mode based on the drive's programmable relay.

Enable Input

- Generally used for safety tie-ins; the motor will not operate the drive or bypass when open.

Common Remote Start/Stop

- Can be used in both drive and bypass mode.

Essential Services Mode

- Typically used for smoke purge; the motor goes to bypass regardless of the selected mode.
- No call to stop will have an effect, including open safety or stop commands.
- Only turning the power off or opening this contact will stop the motor.

Bypass – Door Mounted Control Devices

- Drive-Off-Bypass selector
- Bypass pilot light
- Drive Test On-Off selector

NEMA Type 3R/3RHE Bypass Specifications

Input Voltage (3 phase) 208V, 3 AC $\pm 10\%$ *
 240V, 3 AC $\pm 10\%$ *
 480V, 3 AC $\pm 10\%$
 575V, 3 AC $\pm 10\%$ *

* Not available in the 3RHE models

Protection Level NEMA Type 3R

Temperature

Operating..... 14°F to 104°F (–10°C to 40°C), HT1 to 122°F (50°C)
 Storage..... –40°F to 158°F (–40°C to 70°C)

High-Temperature Model (HT1 and HT2)

Operating..... 14°F to 122°F (–10°C to 50°C)
 Storage..... –40°F to 158°F (–40°C to 70°C)

Humidity 0 to 95% rh, non-condensing

Drive Specifications

Input Voltage and Power Ranges (3 phase) Amps

200V and 230V to 240V,
 3 AC $\pm 10\%$ 1 hp to 60 hp (2.3 Amps to 154 Amps)
 380V to 480V, 3 AC $\pm 10\%$ 1 hp to 125 hp (1.2 Amps to 178 Amps)
 500V to 600V, 3 AC $\pm 10\%$ 1 hp to 125 hp (2.3 Amps to 125 Amps)

Input Frequency 47 Hz to 63 Hz

Output Frequency 0 Hz to 150 Hz

Power Factor ≥ 0.9 total, ≥ 0.97 displacement

VFD Degree of Efficiency 96% to 97%

Switch-on Current Less than nominal input current

Auxiliary Supply 24V Galvanically separated, unregulated
 auxiliary supply (18V to 32V) 100 mA

Overload Capacity 110% for 60 seconds

Control Method Linear, parabolic and programmable V/f;
 and flux current control low-power mode

PWM Frequency 2k Hz to 16k Hz (adjustable in 2k Hz increments)

Fixed Frequencies 15 programmable

Skip Frequency Bands 4 programmable

Setpoint Resolution 0.01 Hz digital
 0.01 Hz serial
 10 bit analog

Digital Inputs (sink/source) 6: fully programmable and scalable
 isolated digital inputs, switchable

Analog Inputs 2: 0 to 10 Vdc, 0/4 mA to 20 mA, can also be
 configured as digital inputs or Ni 1000 input

Relay Outputs 2: configurable 30 Vdc/5A (resistive),
 250 Vac 2A (inductive)

Analog Outputs 2: programmable
 (0/4 mA to 20 mA or 0V to 10 Vdc)

Serial Interface RS-485;
 Protocols: Siemens, P1 and Johnson, N2;
 Transmission Rate Up to 38.4k Baud

Temperature Ranges

Operating..... 14°F to 104°F (–10°C to 40°C)
 Storage..... –40°F to 158°F (–40°C to 70°C)

Humidity 95% rh, non-condensing

Operational Altitudes Up to 3280 ft (1000 m)
 above sea level without derating

Protection Features Under-voltage, Over-voltage, Overload,
 Ground fault, Short circuit, Stall prevention,
 Locked motor, Motor overtemperature I²t PTC,
 Over-temperature, Parameter PIN protection.

Standards UL, cUL

CE Conformity Conformity with EC Low Voltage
 Directive 73/23/EEC

Options LON Interface, Modbus Interface,
 BACnet MS/TP Interface,
 Advanced Operator Panel (AOP) Module,
 PC Kit

VFD NEMA Type 3R & Type 3R Harsh Environment (3RHE) Bypass Product Ordering

Your Product Number																	
Example Product Number		V	B	A	3	4	0	.	F	3	3	0	X	H	E	2	
Model																	
VB	VFD with Bypass																
Series																	
A	Conventional Bypass																
Voltage																	
1	208 V																
2	230 to 240 V																
3	380 to 480 V																
4	500 to 600 V																
HP rating																	
	1.0, 1.5, 2.0, 3.0, 4.0, 5.0, 7.5, 10, 15, 20, 25, 30, 40, 50, 60, 75, 100, 125 [See Note 1 for these selections]																
Disconnect																	
F	Fused Disconnect																
NEMA rating																	
3	NEMA Type 3R																
Contactors																	
0	None																
3	3 Contactors																
Reactor		[See Note 2]															
0	None																
3	Line Reactor																
Filter																	
X	Factory Required Designator																
Options		(If no option is required, leave field blank)															
HT1	High Temperature [See note 3]																
HE2	Harsh Environment Nema 3R [See note 4]																
HT2	Harsh Environment Nema 3R — High Temperature Rating [See note 5]																

Notes:

1. Available only with Voltage Codes 3 and 4.
2. Input line reactors will be installed in bypass enclosures. Load reactors are supplied separately in NEMA 1 or NEMA 3R enclosures.
3. HT1 (122°F, 50°C) is not available for all ratings. 208V and 230 to 240V to 3 hp are all HT1; 480V to 5 hp are all HT1.
4. HE2 available only with Voltage Codes 3 and 4. (480V to 40 hp)
5. HT2 (122°F, 50°C) is not available for all ratings. 480V to 5 hp are all HT2

Example Shown:

VBA340.F330XHE2

VBA Conventional Bypass, 480V, 40 hp, fused disconnect, NEMA Type 3R, 3 contactors, no reactor, harsh environment.

NEMA Type 3R Enclosure Dimensions

Enclosure Frame ABC

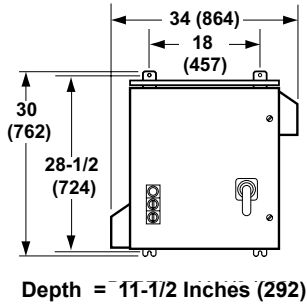

Enclosure Frame DE

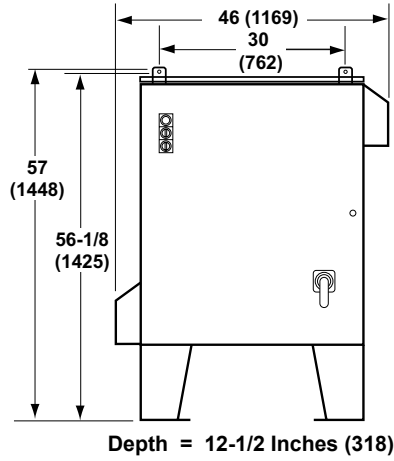

Enclosure Frame F

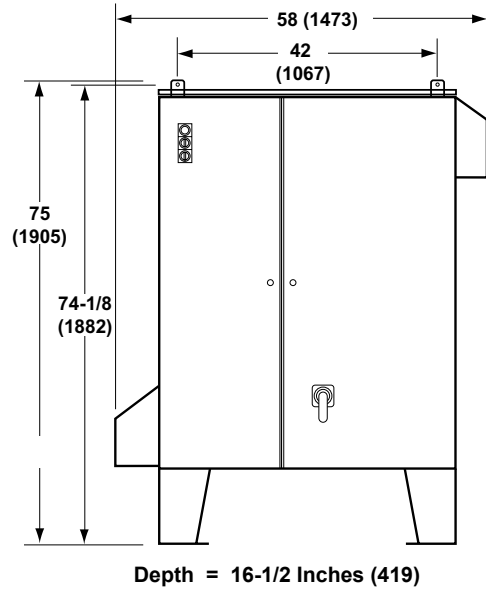

MOUNTING CLEARANCE FOR PROPER AIRFLOW:
LEAVE 1 FOOT (305 mm) BETWEEN THE NEMA TYPE 3R BYPASS AND ANY ADJACENT SOLID STRUCTURE THAT IS NOT USED FOR MOUNTING PURPOSES.

LEAVE 3 FEET (914 mm) BETWEEN THE NEMA TYPE 3R BYPASS AND ANY OTHER NEMA TYPE 3R BYPASS OR VFD.

F-22

VFD0178R2

NEMA Type 3RHE Enclosure Dimensions

Enclosure Frame B

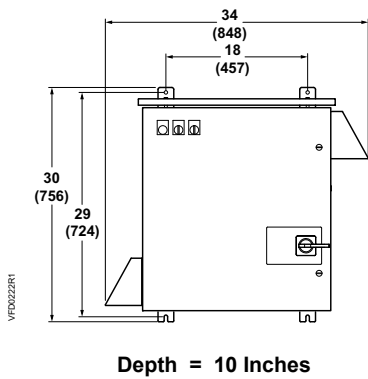

Enclosure Frame C

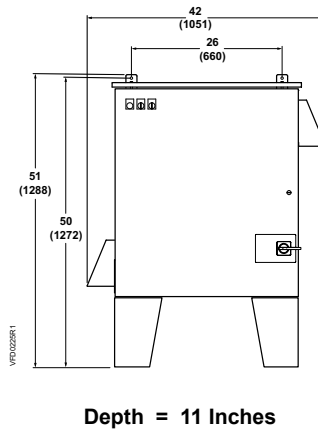

Enclosure Frame D

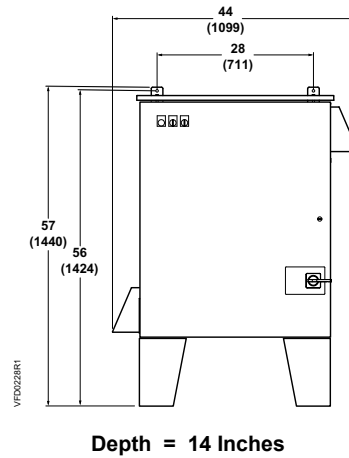

Dimensions shown in inches (mm).

NEMA Type 3R and 3RHE Approximate Weights

3R Frame Size	Wt. Lb (kg)
ABC	130 (59)
DE	300 (136)
F	550 (249)

3RHE Frame Size	Wt. Lb (kg)
B	150 (68)
C	220 (100)
D	330 (150)

Note: Exact weight will be affected by actual horsepower/voltage and selected power options

NEMA Type 3R Bypass Non-HT1 Enclosure Frame Sizes and Power Ranges

HP	1	1.5	2	3	4	5	7.5	10	15	20	25	30	40	50	60	75	100	125
kW	.75	1.1	1.5	2.2	3	4	5.5	7.5	11	15	18.5	22	30	37	45	55	75	90
208/240V	(Rated as HT1, High Temperature package)						ABC			DE			F			N/A		
480V	(Rated as HT1, High Temperature package)						ABC			DE			F			N/A		
575V	ABC						DE			F			N/A					

VFD0179R2

F-23

NEMA Type 3R Bypass HT1 Enclosure Frame Sizes and Power Ranges

HP	1	1.5	2	3	4	5	7.5	10	15	20	25	30	40	50	60	75	100	125
kW	.75	1.1	1.5	2.2	3	4	5.5	7.5	11	15	18.5	22	30	37	45	55	75	90
208/240V	ABC						DE			F			N/A					
480V	ABC						DE			F			N/A					
575V	ABC						DE			F			N/A					

VFD0180R2

NEMA 3RHE Bypasses HE2 Frame Sizes and Power Ranges

HP	1	1.5	2	3	4	5	7.5	10	15	20	25	30	40	50	60	75	100	125
kW	.75	1.1	1.5	2.2	3	4	5.5	7.5	11	15	18.5	22	30	37	45	55	75	90
208/240V	N/A																	
480V	N/A						C			D			N/A					
575V	N/A																	

VFD0180R2

NEMA 3RHE Bypasses HT2 Frame Sizes and Power Ranges

HP	1	1.5	2	3	4	5	7.5	10	15	20	25	30	40	50	60	75	100	125
kW	.75	1.1	1.5	2.2	3	4	5.5	7.5	11	15	18.5	22	30	37	45	55	75	90
208/240V	N/A																	
480V	N/A	B				C			D			N/A						
575V	N/A																	

VFD0180R2

Variable Frequency Drives

We're happy to assist you.

Our customer support teams are accessible and happy to assist you with ordering, fulfillment, and shipping questions. Call a representative at 1-888-593-7876 from 7 am to 5:30 pm (CST) Monday through Friday. Or, send an email to order.management.us.sbt@siemens.com

Contact Customer Support or your Account Executive any time -- we appreciate your business and look forward to helping you!









Table of Contents

PRODUCT	PAGE #
SED2	
Mounting Hardware	F-26
Filter Kits	F-26
Operator Panel	F-26
LON Interface Option	F-27
Modbus Interface	F-27
BACnet Interface	F-27

F-25





Variable Frequency Drives

Accessories and Service Kits

	Description	Part No.
SED2		
	PC Kit.	SED2-PC-KIT
	Gland Plates. (included with NEMA Type 1)	
	• Frame A	SED2-GL-A
	• Frame B	SED2-GL-B
	• Frame C	SED2-GL-C
	Protection Shield. (included with NEMA Type 1)	
	• Frame A	SED2-PS-A
	• Frame B	SED2-PS-B
	• Frame C	SED2-PS-C
	• Frame D, E	SED2-PS-DE
	NEMA Type 1 and 3R Enclosed Reactors.	Contact Sales Partners
	NEMA Type 3R Floor Mounting Kit.	
	• Frames A, B, C	994-809
	BOP/AOP Door Mounting Kits.	
	• BOP/AOP Single Inverter	SED2-DOOR-KIT1
	• AOP Multi-Inverter	SED2-DOOR-KIT2
	EMC Filter Kit.	
	• For use with E-Bypass Frames A & B	994-975
	• For use with E-Bypass Frame C	994-976
	• For use with E-Bypass Frames D & E	994-977
	• For use with E-Bypass Frame F	994-978
	Operator Panel.	
	• Basic Operator Panel (included with all SED2s)	SED2-BOP1
	• Advanced Operator Panel (AOP)	SED2-AOP1

F-26

Variable Frequency Drives

	Description	Part No.
<p>SED2</p> 	<p>LON Interface Option.</p>	<p>SED2-LONI/F</p>
	<p>Modbus RTU Interface Module for SED2. Converts VFD's USS bus to Modbus RTU.</p>	<p>SED2-MOVBUS2</p>
	<p>SED2 Modbus Configuration Kit.</p>	<p>SED2-MOVBUS_KIT</p>
	<p>SED2 BACnet Interface.</p>	<p>Contact Factory</p>

