

Table of Contents

PRODUCT	PRODUCT CODE	TECHNICAL INSTRUCTIONS	PAGE #
Pneumatic Auxiliary Equipment			
Air Station Equipment	201/656/908	155-005/049/086/137P25	H-3
Pressure Gauges	GA142AP	155-025P25	H-7
External Restrictors	184	155-213P25	H-9
Pneumatic Tube Fitting Kit	141	155-108P25	H-13
Controls Cabinet			
Controls Cabinet	CP 567	155-272P25	H-15
Accessories & Service Kits			H-17

Standard Shipping within 3 to 5 days Products ordered through the Rapid Response™ program can ship same day. Expect longer lead times for large quantities and unique parts. See page 2 for details on Rapid Response™ shipping.

Fast Shipping with our Rapid Response Program.



Look for this icon on our most critical and commonly ordered products and you'll know it is available for same-day shipping through our Rapid Response program.

How does Rapid Response work?

- Call Customer Service M-F at 1-888-593-7876 by 2 p.m. Central Standard Time
- Specify overnight shipping
- At no additional charge, the product you need ships the same day

**Only available for continental United States; not available on emailed, online or faxed orders.*



Air Station Equipment



656-0009
High Capacity, 3-way Pilot Valve.



201-1000 Single-stage,
Compressed Air Pressure Reducing Valve.



908-051
Compressed Air Filter.

Description

Providing pneumatic control, Air Station Equipment, which includes Single- and Dual-stage Pressure Reducing Valves and High Capacity, 3-way Pilot Valves, responds rapidly to large volume demands and supply pressure variations. The Compressed Air Filter removes water or oil to 0.025 particle size.

Features

Pressure Reducing Valve

- 200 mesh stainless strainer
- Locking handle
- Dual tappings for right or left-hand gauge (201-1000)
- Gauge plug and bushing
- 2-1/2" (64 mm) gauge with 0 to 30 psig (0 to 207 kPa) (201-1001, 201-1002)

Compressed Air Filter

- 10 scfm (17 m³/hr) capacity
- Drain port
- Replaceable cartridge

Applications

Air Station Equipment and compressor systems are available for schools, hospitals, commercial office and industrial buildings, and other facilities.

Compressed air systems include:

- Single (low) pressure
- Dual (low and high) pressure
- Dual, low pressure for two pressure systems

Your local Siemens Building Technologies representative can assist you in selecting the appropriate air compressors and accessories for optimum efficiency and duty cycling.

Air Station Equipment Specifications

Single-stage, Compressed Air Pressure Reducing Valve, 201-1000

Capacity 8 scfm (17 m³/hr)
 Maximum Inlet Pressure 250 psig (1734 kPa)
 Reducing Pressure Range 0 to 50 psig (0 to 345 kPa)
 Inlet/Outlet Connections 1/4" NPT Female
 Gauge Port 1/4" NPT Male x 1/8" NPT Female bushing
 Shipping Weight 1.7 lb. (0.8 kg)

Compressed Air Filter, 908-051

Capacity 10 scfm (17 m³/hr)
 Maximum Pressure 150 psig (1034 kPa)
 Inlet/Outlet Ports 3/8" NPT Female
 Shipping Weight 2.1 lb. (0.95 kg)

High Capacity, 3-way Pilot Valve

Application Two-pressure systems/
 Day-Night or Heat-Cool
 Inlet/Outlet Ports 1/2" (12 mm) O.D. SAE flare
 Pilot Port 1/8" NPT Female
 Actuator 3 to 8 psi, 10 to 15 psi (69 to 103 kPa)
 Valve Specifications Cv=2.5, 14 scfm (24 m³/s) based on
 18 psig (124 kPa) with a 1 psi (7 kPa) pressure drop
 Shipping Weight 2.0 lb. (0.9 kg)

High Capacity, 3-way Pilot Valve

Application Two-pressure systems/
 Day-Night or Heat-Cool
 Inlet/Outlet Ports 1/2" (13 mm) O.D. SAE flare
 Pilot Port 1/8" NPT Female
 Actuator 3 to 8 psi (21 to 55 kPa)
 Valve Specifications Cv=2.5, 14 scfm (24 m³/s) based on
 18 psig (124 kPa) with a 1 psi (7 kPa) pressure drop
 Shipping Weight 2.0 lb. (0.9 kg)

H-4

Auxiliary Equipment

Air Station Equipment Product Ordering

Description	Part No.
Single-stage, Compressed Air Pressure Reducing Valve	201-1000
Compressed Air Filter	908-051
High Capacity, 3-way Pilot Valve (10 to 15 psi)	656-0009
High Capacity, 3-way, Pilot Valve (3 to 8 psi)	656-0010

Accessories & Service Kits

H-17

Application Drawings

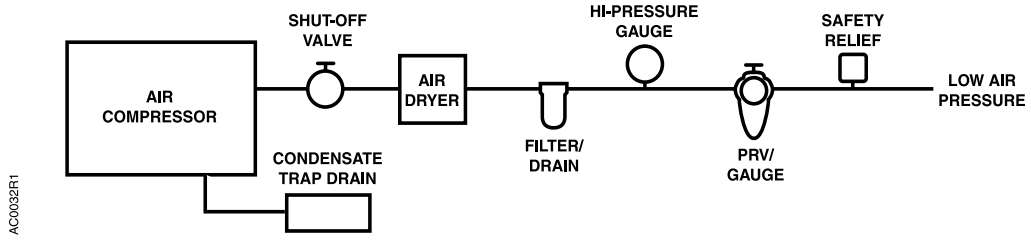

Single Pressure.

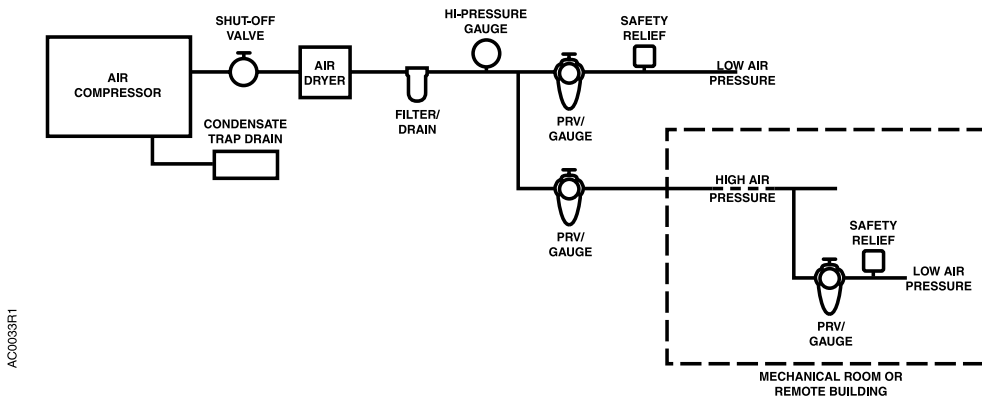

Low and High Pressure.

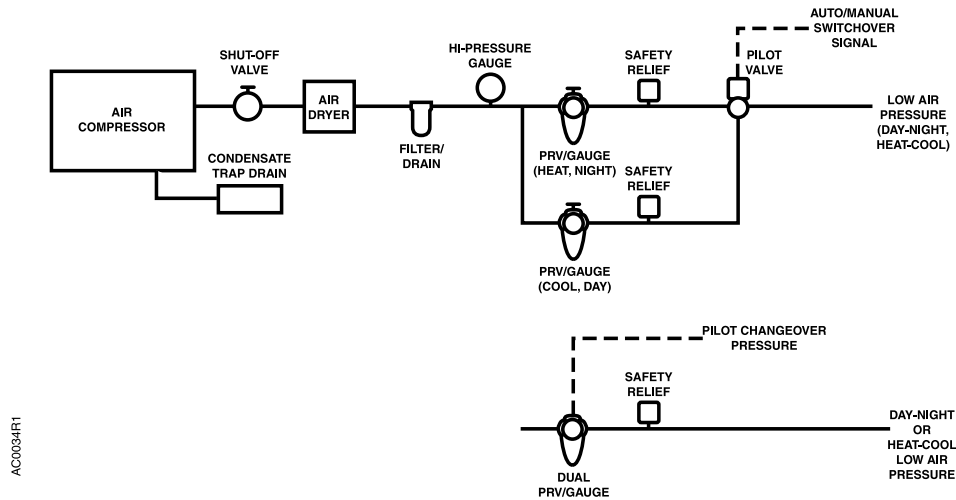

Dual Pressure.

Easy and convenient online ordering at www.usa.siemens.com/hvac

Shop and select from our complete line of HVAC building controls.
Our online ordering tool helps you save time:

- Search for products by part number or description
- Check availability and pricing
- Print out product information for submittals
- Link to technical documentation
- Download installation instructions
- Create a reusable template order form for frequently ordered parts

www.usa.siemens.com/buildingtechnologiesonlineordering



Pressure Gauges

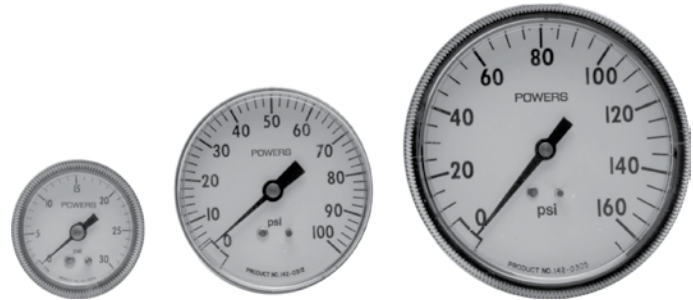

1-1/2", 2-1/2" and 3-1/2" Pressure Gauges.

Description

Pneumatic pressure gauges are used wherever visual indication of pressure is required.

Features

- Accuracy 2.5% of full scale for the middle half of scale; 3.5% elsewhere
- Available in 1-1/2-inch (38 mm), 2-1/2-inch (64 mm) and 3-1/2-inch (89 mm) diameter sizes
- Mounting hardware for panel mounted gauges included

Applications

The 142 AP Pressure Gauges are generally used in applications such as air compressor stations and central control panels.

H-7

Auxiliary Equipment

Pressure Gauge Specifications

Accuracy 2-1/2% of full scale for middle half of the scale, 3-1/2% elsewhere
Connection 1/8" NPT male or barbed connector for 1/4" (6 mm) O.D. tubing

Shipping Weights
 1-1/2" 0.5 lb. (0.23 kg)
 2-1/2" 1.0 lb. (0.45 kg)
 3-1/2" 1.3 lb. (0.59 kg)

For more information on receiver gauges, refer to the Controllers and Transmitters, Section C.

Pressure Gauge Product Ordering

Range	Description	Part No.	
		1-1/2"	2-1/2"
English			
0 to 30 psi	Barb panel	142-0274	142-0277
0 to 30 psi/0 to 200 kPa	NPT male-bottom	142-0426	—
0 to 200 kPa/0 to 30 psi	NPT male-back	142-0373	142-0311
0 to 100 psi	NPT male back-panel	—	—
0 to 100 psi	NPT male back-pipe	—	142-0312
0 to 160 psi	NPT male-back-pipe	—	142-0313
Metric			
0 to 206.8 kPa	Barb	142-0331	—
0 to 206.8 kPa	Pipe	142-0344	—

Table Note

Hole sizes for panel mounted gauges are: 1-1/2"/1-11/16"; 2-1/2"/2-21/32" and 3-1/2"/3-11/16" (Gauge Size/Hole Size).

Siemens Warranty.

Most products you purchase from us are backed with a 2-year warranty from the date of manufacture. Variable Frequency Drives carry an 18-month product warranty from their date of shipment. Certified Startup products offer a 3-year warranty from date of shipment.

External Restrictors



In-line Threaded Restrictor.



In-line Barbed Restrictor.



Tee Barbed Restrictor.

Description

Restrictors are available in a variety of orifice sizes and connection types.

Features

External Types 1, 2 and 3

- Air filter
- 1/8-inch NPT threaded connection (Type 1)
- Barbed connection for 1/4-inch (6 mm) plastic tubing (Types 2 and 3)
- Color-coded (Types 2 and 3)
- Air flow direction arrow to minimize installation errors
- Air flow restrictor capacity molded (Types 2 and 3) or stamped (Type 1) on body

Applications

External restrictors are used:

- For 1-pipe room thermostats, 20 scim (5.5 ml/s), refer to Figure 3.
- For 1-pipe transmitters, 40 scim (11 ml/s), refer to Figures 1 and 2.
- When installed tubing lengths exceed maximum recommended values, refer to Figure 2.
- With check valves to provide air flow time delays:
 - Slow to supply, fast to exhaust, refer to Figure 4.
 - Fast to supply, slow to exhaust, refer to Figure 5.
- VAV vortex control. Use 80 scim (22 ml/s) restrictor in positioning relay control pressure line to prevent cycling.
- When other air capacities, 10 scim (2.7 ml/s), 80 scim (22 ml/s), or 320 scim (87 ml/s) are required to compensate for tubing size or response time.

Figures are on page H-11.



Typical Connections

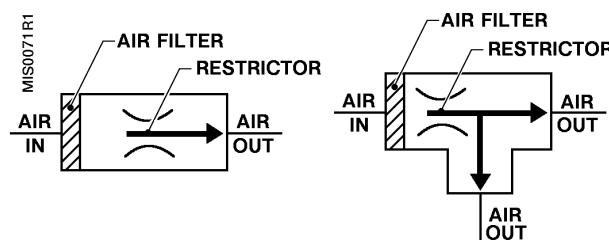

Restrictor Specifications

Materials

Type 1..... Brass
 Type 2 and 3..... Plastic

Air Connections

Type 1..... 1/8" NPT thread
 Type 2 and 3..... Barb for 1/4" (6 mm) OD polyethylene tubing

Ambient Temperature

Minimum..... 40°F (4°C)
 Maximum..... 140°F (60°C)

Mounting

..... In-line

Flow Capacity at Various Air Pressure Drop

Air Pressure	% of Max. Flow Capacity	Nominal Capacity				
		10	20	40	80	320
22 psi (152 kPa)	100%	10 scim (2.7 ml/s)	20 scim (5.5 ml/s)	40 scim (11 ml/s)	80 scim (87 ml/s)	320 scim (87 ml/s)
10 psi (69 kPa)	70%	7 scim (1.9 ml/s)	14 scim (3.8 ml/s)	28 scim (7.6 ml/s)	56 scim (15 ml/s)	224 scim (61 ml/s)
5 psi (34 kPa)	50%	5 scim (1.4 ml/s)	10 scim (2.7 ml/s)	20 scim (5.5 ml/s)	40 scim (11 ml/s)	160 scim (44 ml/s)
2.5 psi (17 kPa)	35%	3.5 scim (1.0 ml/s)	7 scim (1.9 ml/s)	14 scim (3.8 ml/s)	28 scim (7.6 ml/s)	112 scim (31 ml/s)

Restrictor Product Ordering

Nominal Air Capacity	Orifice Diameter	Part No.			Barbed Restrictor Body Color
		Type 1 In-line Threaded (Pkg. of 1)	Type 2 In-line Barbed (Pkg. of 5)	Type 3 Tee Barbed (Pkg. of 5)	
10 scim (2.7 ml/s)	0.0035" (0.09 mm)	—	184-115	184-112	Red
20 scim (5.5 ml/s)	0.0051" (0.13 mm)	184-040	184-116	184-113	Yellow
40 scim (11 ml/s)	0.0074" (0.19 mm)	184-041	184-117	184-114	Green
80 scim (22 ml/s)	0.0098" (0.25 mm)	184-042	—	—	—
320 scim (87 ml/s)	0.0201" (0.51 mm)	184-052	—	—	—

If inoperative, replace the unit.

Dimensions

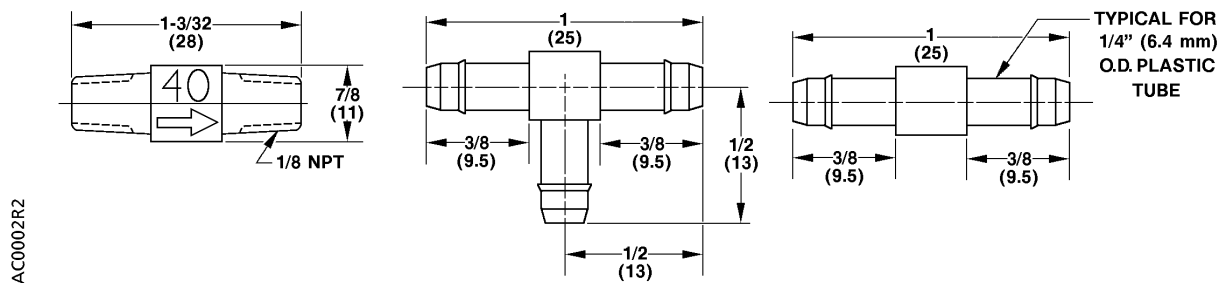

Dimensions shown in inches (mm).

H-10

Auxiliary Equipment

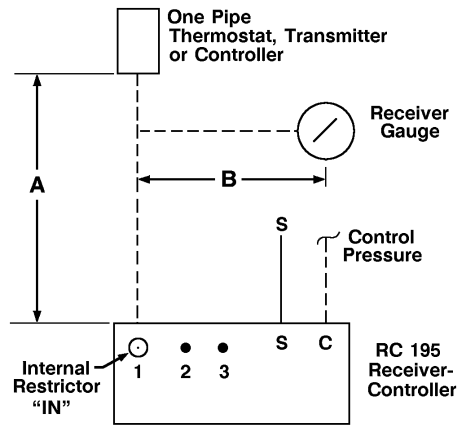

Figure 1.

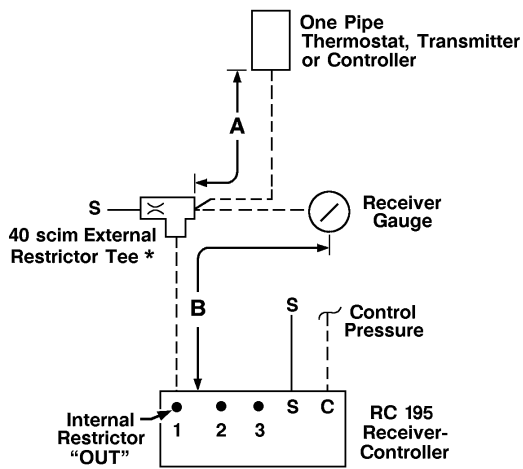

Figure 2.

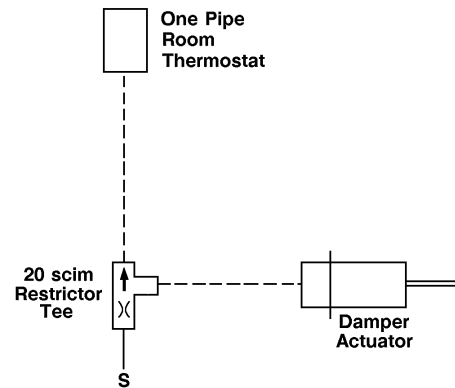

Figure 3.

* Use External Restrictor with RC195 when "A" length exceeds 300 ft. (91 m) or when "A & B" length exceeds 1,000 ft. (305 m).

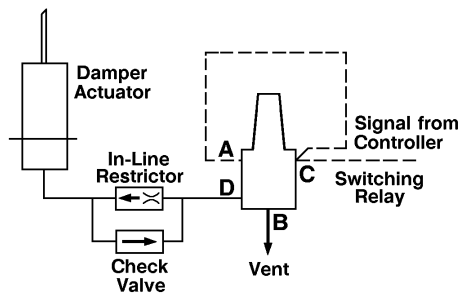

Figure 4.

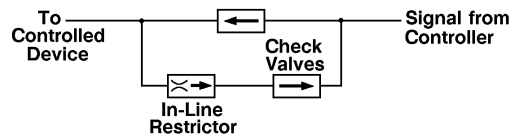

Figure 5.

Place orders online 24/7.

Use this Master HVAC Catalog and Siemens online ordering to maximize ordering efficiency. Go online to:

- Place orders
- Browse this catalog online
- Check product availability and pricing
- Specify FREE valve tagging
- Download invoices
- Track shipments
- Print out product information for submittals
- Link to technical documentation
- Download installation instructions
- Create a reusable template order form for frequently ordered parts

See how easy it is today to save time and money. Register today at:
www.usa.siemens.com/buildingtechnologiesonlineordering



Pneumatic Tube Fitting Kit



141-0601 Pneumatic Tube Fitting Kit.



141-464 Case.

Description

The Pneumatic Tube Fitting Kit provides the service or installation mechanic with a compact and convenient source of the most commonly used brass barbed fittings for 1/4-inch (6 mm), 3/8-inch (10 mm) and 1/2-inch (13 mm) OD polyethylene tubing.

Features

- Rustproof, odor and oil resistant case
- Translucent lid for easy identification of fittings
- Double positive latches
- 15 dividers for configuring up to 24 compartments
- Lower cost for fittings
- Representative quantities of commonly used 1/4-inch (6 mm), 3/8-inch (10 mm) and 1/2-inch (13 mm) brass fittings

Applications

The Pneumatic Tube Fitting Kit is useful for servicing, modifying, or adding to pneumatic control systems. Purchasing in quantity reduces material costs. Labor savings is the major reason to have this convenient kit in your service shop or van.

H-13

Auxiliary Equipment







Pneumatic Tube Fitting Kit Specifications

Case MaterialCopolymer Resin
 Dimensions 15" L x 11.75" W x 2.5" D
 (381 mm L x 298 mm W x 64 mm D)
 Shipping Weight
 Case3.0 lb. (1.4 kg)
 Case and Fittings7.0 lb. (3.2 kg)

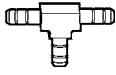
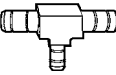
Other Supplies and Equipment

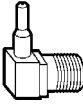
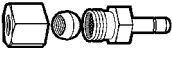
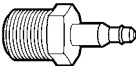
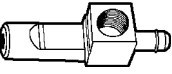
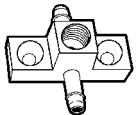
The fittings in this kit represent most of the commonly used polyethylene tube fittings required by HVAC mechanics.

Kit Includes:

	Description	Quantity
	Barbed Tee. • 1/4" (6 mm) • 3/8" (10 mm) • 1/2" (13 mm)	12 6 6
	1/4" (6 mm) Barbed Reducing Tee. • 3/8" (10 mm) • 1/2" (13 mm)	6 6
	90° Elbow. • 1/4" (6 mm) • 3/8" (10 mm) • 1/2" (13 mm)	12 6 6
	1/8" NPT Male x 90° Elbow. • 1/4" (6 mm) or 5/32" (4 mm)	12
	1/4" (6 mm) OD Copper Coupling. • 1/4" (6 mm)	10
	1/8" NPT Male. • 1/4" (6 mm)	10
	Gauge Tee 1/8" NPT Male/NPT Female. • 1/4" (6 mm)	10
	Gauge Tee 1/8" NPT Female. • 1/4" (6 mm)	5
	Plug. • 1/4" (6 mm)	10
	Reducer Coupling OD. • 1/4" (6 mm)	10
	Coupling. • 1/4" (6 mm) • 3/8" (10 mm) • 1/2" (13 mm)	12 10 10

Pneumatic Tube Fitting Kit Product Ordering

Description	Part No.
Complete Kit with 159 fittings	141-0601
Case only	141-464

H-14

Auxiliary Equipment

Accessories & Service Kits

H-17

Controls Cabinet/Enclosure



567-351 Exposed Panel Assembly.

Description

Designed to conveniently group control system components, 567 Controls Cabinets are available in two styles, exposed and flush mount.

With the exposed panels, the control components can be mounted in the door or mounted within the enclosure using the perforated panel. The cabinet housing, door, and perforated mounting plate may be ordered as a unit or separately.

The flush mount panel is designed to recess the panel into a wall. The controls are mounted within the enclosures on a perforated panel. Order both the cabinet and the mounting kit.

Features

- Panels are symmetrical, and can be mounted with door hinge on left or right-hand side
- Removable door with lock and keys
- Removable perforated subpanel permits mounting controls without drilling holes
- Attractive gray finish permits use in occupied areas
- Support kit is available for floor mounting (medium and large exposed cabinets only)
- Variety of mounting methods available
- Knockouts are provided for electrical or pneumatic piping
- Panels listed under UL508 Industrial Control Panel Enclosures
- CSA listed under LR 84214
- NEMA Type 1
- Exposed Panels available in 6" or 9" depth

Applications

The 567 Controls Cabinets provide a convenient central location for equipment mounting, termination of piping, wiring adjustment, and calibration.

Panels may be used with DDC and/or pneumatic systems using either copper or polyethylene tubing for transmission lines, with wired electric/electronic systems, or with a combination of both. Within the panel enclosure, use polyethylene pneumatic tubing for easy installation and arrangement and for a flexible connection to hinged door components.

The empty panel can be installed at the job to permit early rough-in of conduit. Since the door and subpanel can be separated from the cabinet, controls may be mounted to the door subpanel either at the job site or at the field office and connected to the cabinet at your convenience. After reassembly, final connections are then made.

H-15

Auxiliary Equipment

567 Controls Cabinet Specifications

Exposed Panel

Dimensions — 9" Depth

- Size 3: 24.94" H x 24.38" W x 9.38" D
(633 mm H x 619 mm W x 238 mm D)
- Size 4: 36.5" H x 24.38" W x 9.38" D
(927 mm H x 619 mm W x 238 mm D)

Dimensions — 6" Depth

- Size 1: 19.5" H x 16.38" W x 5.75" D
(495 mm H x 416 mm W x 146 mm D)
- Size 2: 20.0" H x 20.0" W x 6.0" D
(508 mm H x 508 mm W x 152 mm D)
- Size 3: 24.94" H x 24.38" W x 6.0" D
(633 mm H x 619 mm W x 152 mm D)
- Size 4: 36.5" H x 24.38" W x 6.0" D
(927 mm H x 619 mm W x 152 mm D)

Shipping Weights — 9" Depth

- Size 3: 39.0 lb. (18 kg)
- Size 4: 72.0 lb. (33 kg)

Shipping Weights — 6" Depth

- Size 1: 20.0 lb. (9 kg)
- Size 2: 28.0 lb. (13 kg)
- Size 3: 38.0 lb. (17 kg)
- Size 4: 63.0 lb. (29 kg)

Flush Mount Panel — 567-391

Dimensions 19.5" H x 16.13" W x 5.13" D
(495 mm H x 410 mm W x 130 mm D)

Shipping Weight 20.0 lb. (9 kg)

Panel Door

Shipping Weights

- Size 1: 8.0 lb. (3.6 kg)
- Size 3: 13.0 lb. (5.9 kg)
- Size 4: 20.0 lb. (9 kg)

H-16

Auxiliary Equipment

567 Controls Cabinet Product Ordering

Size	Part No. — 9"	Part No. — 6"
Exposed Panel Assembly		
Size 1	—	567-351
Size 2	—	567-454
Size 3	567-352	567-452
Size 4	567-353	567-453
Panel Door Only		
Size 1	567-361	—
Size 3	567-362	—
Size 4	567-363	—
Panel Enclosure		
Size 1	567-371	—
Size 3	567-372	—
Size 4	567-373	—
Mounting Plate Only		
Size 1	567-381	—
Size 3	567-382	—
Size 4	567-383	—
Flush Mount Panel & Kit		
Flush Mount Panel	567-391	—
Flush Mount Kit contains escutcheon, hinged locking door and two keys	567-390	—



Accessories & Service Kits H-19



Part No. in black box Ships same day when requested through Rapid Response™ shipping. See page 2 for details.











Table of Contents

PRODUCT	PAGE #
Multiple Applications	
Check Valves	H-18
Tube Clamps/Adapters	H-18
Air Station Equipment	
Air Filter Replacements	H-18
TM894 Thermometers	
Thermometers	H-18
Well/Bulb Holder	H-18
CP567 Control Panels	
Mounting Kits	H-19
Replacement Parts	H-19

H-17

Auxiliary Equipment



Accessories & Service Kits

	Description	Product Group	Quantity	Part No.
Multiple Applications				
	Check Valve. Connections for 1/4" (6 mm) OD polyethylene tubing. Capacity is 30 scim (8.2 ml/sec) at 1 psi (7 kPa) drop. 450 scim (123 ml/sec) at 8 psi (55 kPa) drop.	Multiple Applications	Package of 10	380-024
	Copper to Polyethylene Tubing Adapters. 24" length. Adapts 1/4" (6 mm) OD polyethylene tubing to 1/4" (6 mm) OD copper tubing. Eliminates the need for compression fitting.	Multiple Applications	Package of 50	141-426
	Pneumatic Spring Clamp.	Multiple Applications	1	531-833
Air Station Equipment				
	Air Filter Replacement Element. For use with 908-051.	Air Station Equipment	1	908-052
	Compressed Air Mini Filter. For use with Air Station Equipment.	Air Station Equipment	1	908-033
	Cartridge Kit. For use with 1 908-046 Filter. 500 scim (137 ml/sec) with 25 psi (127 kPa) supply for oil removal.	Air Station Equipment	1	908-042
	Standard Separable Well. (Brass) For 3-1/2" (89 mm) STEM multi-angle thermometer.	TM894	1	894-368
	Bulb Holder. For remote bulb thermometer.	TM894	1	808-517

H-18

Auxiliary Equipment

Accessories & Service Kits

	Description	Product Group	Quantity	Part No.
CP567 Control Panels				
	Floor Mount Support Kit. <ul style="list-style-type: none"> • Medium exposed cabinet 37" (94 cm). Contains 2 supports and hardware. 	CP567	1	567-334
	<ul style="list-style-type: none"> • Large exposed cabinet 49" (125 cm) 		1	567-335
	Replacement Door Lock and Key Assembly.	CP567	1	567-225
	Logo Label.	CP567	1	567-176B

H-19

Auxiliary Equipment

