

SIEMENS

Building Technologies

FireFinder Intelligent Fire Detection and Building Evacuation Systems:

The new standard in speed, simplicity and audio communication.





Next to fire itself, a firefighter's biggest adversary is guesswork.

If there's a fire in your facility, firefighters have just a few seconds to pinpoint its location and identify the whereabouts of occupants and any hazardous materials. This critical time frame makes all the difference between safety and tragedy. To get the information they need, firefighters must read the operator interface screen on your fire detection system panel. But the small screen on most systems can only display a limited amount of text, which often appears as vague abbreviations that can confuse and delay firefighters.

The FireFinder Intelligent Fire Detection System eliminates guesswork by using the world's largest standard fire system screen and unrivaled message capacity to deliver clear, accurate alarm message descriptions. FireFinder is the only system available that can communicate in hundreds of easy-to-read, large-text characters, hazmat icons, maps and NFPA fire safety symbols. All designed to be readily understood by users at all levels, based on the premise that a big picture really is worth a thousand words.

Faster response and easier installation and maintenance.

Along with unmatched message capability, the FireFinder system responds with remarkable speed, detecting and notifying occupants in under 3 seconds.* It's also the easiest intelligent system to install and maintain. System control is tailored to the knowledge level of the operator. Large lighted buttons prompt less familiar users through typical system control sequences. While more knowledgeable users can use the password-protected touch screen to view and control the entire system and locate specific

alarms using a simple sequence of lighted buttons and maps. For installers, the system offers innovative electrical and software features that can help slash installation time by up to 25%.**

Greater flexibility and compatibility.

For the greatest possible protection, the FireFinder system operates with a full range of proven, high-performance devices and systems, including:

- Network Command and Control (NCC) and Wide Area Network Systems (NCCWAN)
- Multiple FireFinder Networking System (compatible with MXL)
- Integrated digital emergency voice evacuation system
- FirePrint intelligent fire detectors
- Special hazards extinguishing systems
- Notification devices

Lower life-cycle cost.

The focus of the FireFinder system is unbeatable accuracy and ease-of-use for your building personnel, installers and firefighters. And all the features that make it so simple to handle are also designed to reduce your costs over the life of the system. From its flexible architecture, to its time-and-money-saving installation features, to its large screen with unrivaled safety and maintenance capabilities.

* Typical

**Depending on size and type of building.



ALARM



SUPERVISORY



SECURITY



TROUBLE



Mfg. floor - Assembly area

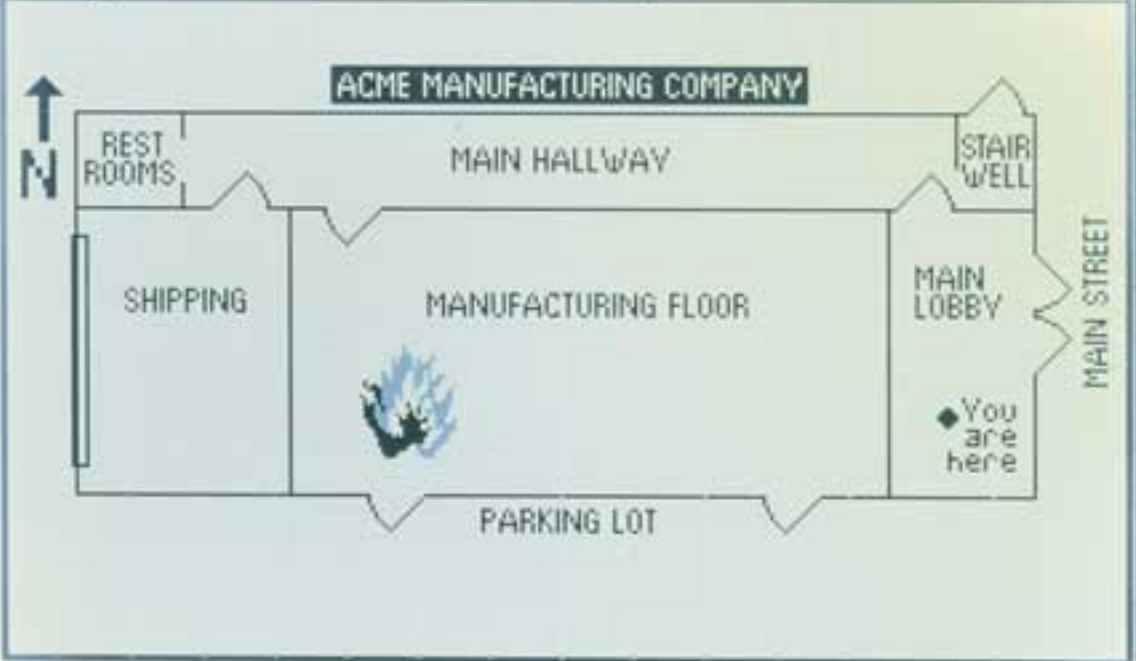

DETAILS

MAP

DEVICES

BACK



VER

N

BLES

NCED

AL SYSTEM
LED

Groundbreaking features mean the greatest possible protection.

The Big Picture.

At 6", the screen on the FireFinder detection system is the largest standard operator interface available in the industry. This feature makes system status much easier to read and understand, especially during a stressful fire emergency. By following the prompts to press a simple sequence of buttons, fire personnel can access all the information they need:

Large-font text messages – Typical screens are limited to 80+ characters, which forces the installer to enter alarm message descriptions in abbreviations that often only the installer can understand. When a real alarm occurs, these cryptic messages can delay firefighters from responding to the correct location. The FireFinder system can handle hundreds of text characters, which allows installers to enter very accurate descriptions. A full-detail screen is dedicated to each event to provide additional text messages and descriptions.

Maps – The large graphical display contains simple maps of a building's floor plan, indicating the location of the activated fire alarm device. Most importantly, it shows the location of responding fire personnel in relation to the fire, indicating "You are here."

Hazmat Icons – Indicate the presence of explosive gas, liquids, poison, fumes, etc., that firefighters might encounter, and the type of occupants typically in the area (children, disabled, bedridden, etc.). Information regarding building exit locations can be indicated to help fire officials evaluate the situation (accessibility, emergency exits, etc.).

Standard NFPA 170 fire safety symbols – Provide firefighters with critical information about the type of fire service equipment available in the alarm area (standpipe connection points, automatic sprinkler connection and control points, area of refuge, hose connection points, etc.).

Simplified interfaces save time, increase control.

Easy operation and maintenance.

Your operations and maintenance personnel must interact with your fire detection system at an even greater level than firefighters. For this reason, we've designed the FireFinder system to represent your facility's layout the way building personnel see it. This helps them perform day-to-day system duties – including running reports, troubleshooting simple problems and making minor changes – with more flexibility and ease than ever. Several important features make this possible:

- **Maintenance Mode** – A single mode using a simple sequence of lighted buttons lets personnel view the entire system, including all modules and devices (each with a custom message), arm and disarm the system, run device sensitivity reports and print review screens. Whether you employ your own maintenance staff or an outside service provider, the time necessary for diagnosis and repairs is drastically reduced.
- **Alarm Location Display** – No address numbers are required because the entire system structure can be viewed and navigated through on the large display by using real device and module locations – rather than needing to know the address numbers of devices.

The FireFinder XLSV with Integrated Digital Emergency Voice Evacuation.



Greater clarity, flexibility and cost savings.

The FireFinder XLSV integrates the latest voice evacuation technology with all the desirable features of the FireFinder XLS. Ideal for highly populated buildings and complexes, the system can deliver crystal-clear multiple and simultaneous messages to various locations. Multi-functional audio channels can be used for emergency evacuation and as an everyday building communications system for convenience paging and background music.

High-quality amplifiers – The system’s powerful, modular amplifiers provide a wider frequency response for intelligible, undistorted voice messages. The amplifiers also deliver the high-quality sound necessary for pleasant background music. Their modular design and power allow the amplifiers to be integrated in the same panel with other FireFinder XLSV modules, which saves on installation costs and space.

8 digital audio channels – To help facilitate faster, more orderly evacuation, the system can broadcast eight different messages or tones simultaneously to different parts of a facility. Messages can be live, or pre-recorded; this allows the system to respond with messages that are specific to the type of emergency, such as fire, tornado, terror alerts or earthquake.

UL864-listed for background music and paging – The FireFinder XLSV meets current NFPA code requirements for music and paging. This cost-saving alternative eliminates the need to install a separate audio system. Remote microphone stations can be installed to work with the paging feature. Even while playing background music, the system is performing its chief function of supervising the speakers to insure proper emergency operation. In an emergency, the voice evacuation feature automatically overrides the other audio features.



FireFinder XLSV



Remote Paging Station

Devices that enhance system performance.



The FirePrint™ Intelligent Fire Detector.

Using a neural network which operates much like the human brain, FirePrint combines the world's largest bank of fire test data with the conditions in your building to decide if a fire situation exists. False alarms are eliminated because the detector knows and recognizes the difference between false alarm conditions and genuine fire. Through the FireFinder system, FirePrint can be set for the type of environment it's detecting. This allows the detector's decision-making process to adjust as needed, looking for the fire scenarios it expects to find in that environment.

FirePrint can be set for any of 11 different environments in which fires are most likely to occur:

Computer room	Office
Dormitory	Parking garage
Healthcare	Precious storage
Hostile environment	Utility room
HVAC duct	Warehouse
Lobby	

Maintenance feature: During system maintenance procedures, there's no need to turn off the entire system. FireFinder has the unique ability to disable *portions* of the FirePrint detector, which allows the device to continue to provide the highest level of protection – even during construction. For example, detectors are typically disarmed to prevent nuisance alarms during construction, leaving critical areas of a building unprotected. With the FireFinder system, the smoke-detecting portion may be disarmed, while the thermal portion may be left on to provide protection at all times.

Special Hazards Environments.

FM-200™ Clean Agent Fire Suppression Systems are the most effective firefighting clean agent systems for any environment in which protection of critical assets is vital. From clean rooms to telecommunications facilities, military installations, chemical storage facilities and critical health care facilities. FM-200 is capable of extinguishing fire within 10 seconds, *without* harming occupants or damaging precious equipment, processes or objects.

Notification Devices.

Developed to meet ISO 9001 quality standards and ADA requirements, this complete line of products is both energy efficient and easy to install. The selection includes speakers, chimes and our newest advancements:

Strobes – This new selectable strobe is the first of its kind with a selector switch on its face rather than on the rear of the product. The exclusive feature will allow installers to change the intensity level of each adapter device after mounting.

Horns – Choose from a variety of reliable, state-of-the-art horn products, including multi-tone electronic models with eight horn outputs, and horns that can be synchronized with a temporal output. The selection also includes explosion-proof, weatherproof and electromechanical horns.

Speakers – With advanced digital technology, the FireFinder XLSV system can provide emergency voice evacuation, and optional convenience paging and background music through the same set of speakers. Choose from ClearSpeak™ state-of-the-art speaker-to-speaker/strobe units for emergency or non-emergency voice evacuation applications.



Command and Control for Multi-System Networks.

Network Command and Control (NCC).

The NCC is a PC-Based Graphic Command Center that provides the customer with one central point for annunciation and control of networked FireFinder systems (or a combination of FireFinder and MXL systems). The NCC can also be expanded to include multiple command centers with the ability to direct control as required. Designed to be compatible with past, present and future Siemens fire detection systems, the NCC allows communication over long distances between remote buildings. This can be done using fiber-optic cable or dedicated wiring, or over unlimited distances using dedicated, data grade phone lines.

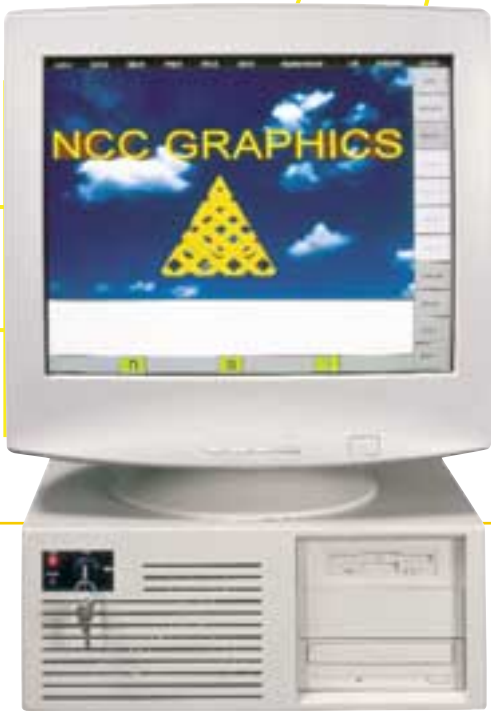

A. Bus Configuration

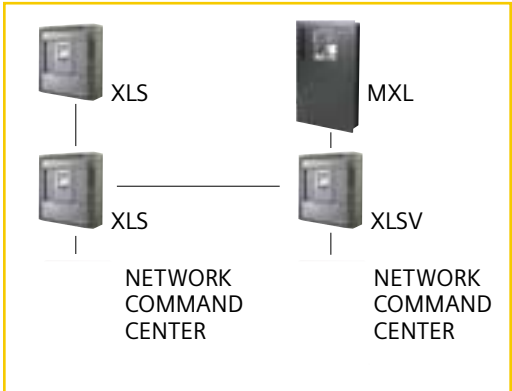



Networking Multiple FireFinder systems.

Ideal for large or high-risk facilities, this peer-to-peer network coordinates multiple FireFinder systems (or FireFinder and MXL systems). Simultaneously, it ensures that each FireFinder control panel performs its own life safety functions independently, providing a high level of system survivability. This includes evacuation and notification of occupants, HVAC control and elevator capture, even if catastrophic failure occurs in another part of the building.

Among its many capabilities, the network can:

- Interface with other building management and control systems.
- Accommodate virtually any size facility by interconnecting up to 64 systems on a single network, providing a system capacity of more than 4,000 nodes and 300K intelligent devices.
- Minimize the risks and costs of faults by automatically compensating for one or many faults in the network communication path.
- Accommodate any building or campus architecture using one of the wiring configurations pictured below.

Network Command Center, Wide Area Network (NCCWAN).

The Network Command Center can also be set up in a wide area network (NCCWAN). This allows multiple buildings to be wired to the Network Command Center in a star configuration through modem communication. Using copper wire, the distance between each building or area and the Network Command Center can be up to eight miles. The distance is unlimited when dedicated data grade phone lines are used. The NCCWAN can also be configured for Local/Global control. In this format, multiple buildings are networked together with their own Network Command Center, but still report over modem communications to the Command Center as one point of contact. Additionally, the NCCWAN may act as a direct replacement for the CXL Command Center.

B. Loop Configuration

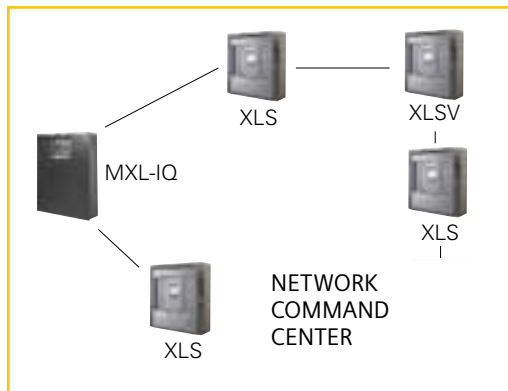

C. Star Configuration

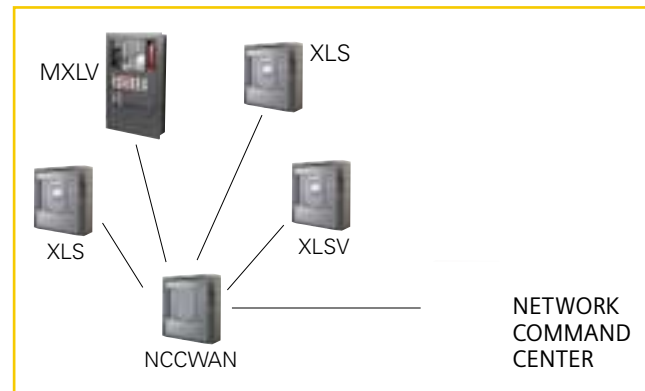

Fast and easy installation.



Hand-held Device Programmer and Loop Tester helps reduce installation time.

Built for speed in every way, the FireFinder system contains revolutionary SureWire technology that can help eliminate installation errors and reduce installation time by up to 25%. This one-of-a-kind technology can also help you reduce labor costs. This technology includes:

Device Programmer and Loop Tester Unit*

(DPU) – FireFinder is the only intelligent system equipped with this powerful tool that will save many hours of installation time! The DPU allows installers to test and verify the correct connection of devices as they are installed instead of waiting until the end of installation to test at the fire panel. It instantly communicates with devices and confirms whether they're functioning properly, reporting individual device addresses, the type of each device, and a summary of total devices on the loop according to type (i.e.: # Manual Stations, # Smoke detectors, etc.). The DPU will also check detector loops for ground faults and shorts.

Polarity Insensitive Detector Loop Wiring

Another big time-saver, polarity insensitive wiring allows fire detection devices to operate flawlessly even when detector and module wiring polarity are inverted on the wrong screw terminals. This feature is so innovative it has been awarded a US patent. When wiring polarity doesn't need to be observed, wiring troubleshooting is greatly reduced.

Ground Fault Detection by Module – Ground faults are easily the most time-consuming wiring problem to locate in a detection system. But the FireFinder system greatly simplifies locating the problem by identifying the specific pair of wires that contain a ground fault.

Use of Any Existing Wire – The system can be connected to existing field device and notification circuit wiring, which saves time and money on retrofits.** To further reduce installation costs, there's no need for shielded wire on intelligent detector loops, notification appliance circuits or telephone circuits which may cause more ground faults.

Windows™ Configuration Program* – A simple, Windows-based configuration tool makes programming faster and easier for all levels of programmers, from system design engineer through installing technician. It also allows configuration programming to be created and changed in less time.

Completely modular - The system's modular construction makes installation and commissioning easier and faster. Each module is designed to accomplish more tasks, so fewer modules and related wiring are required to provide building protection. Modular construction also makes it easier to expand the FireFinder system as a facility grows.

Flexible number of loops – To accommodate the needs of any building, the system's flexible design allows the customer to use fewer input zones with more detection devices, or visa versa.

252 detection devices per input zone – More devices per zone means less wiring to install in a facility. Even when wired to one input zone, the devices can be assigned to separate building zones while still providing short circuit protection*** between building zones.

* Patents pending.

** Use of existing wire requires approval of local authority having jurisdiction.

*** Line isolator required

The fire safety tradition from Siemens: Expertise that helped build an industry.

When it comes to fire detection, we can honestly say we do it all. And in many cases, we've done it first, including introducing the world to the first ionization, analog and field programmable fire detectors.

A member of Siemens Building Technologies, Inc., we're the world's largest manufacturer of fire detection systems. For 50-plus years, we've designed solutions for virtually every type and size of facility, protecting lives and business operation worldwide. Our market leadership is built on long-term customer relationships, and solidified by a commitment to R&D, consistent value and customer-driven solutions.

Learn how our big-screen system can bring you big savings and big peace-of-mind. Call Siemens Building Technologies, Fire Safety Division at 973-593-2600 or visit sbt.siemens.com/fis

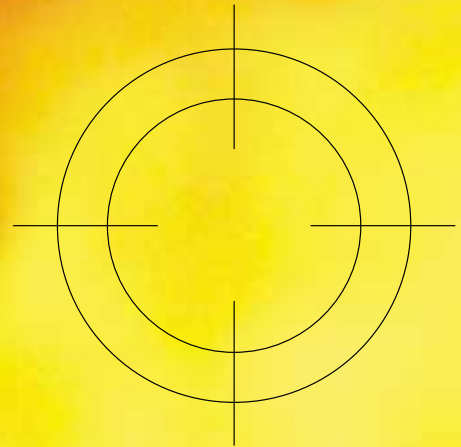

A new record in detection and response speed.

Nothing acts to protect your facility and its occupants like the FireFinder system. When a fire is detected, the system relays the message from the point of detection to the fire panel in less than a quarter of a second. Within 3 seconds,* alarms are activated and emergency control operations are engaged, including fire door closure, elevator capture and air handler shut off.

Simultaneously, the large display screen on the fire panel communicates the critical information fire fighters need, using detailed text messages and visuals like a fire locator map, Hazmat icons and NFPA symbols.

Each FireFinder panel packs enough power to handle all signals and other emergency operations. There is no need for costly auxiliary power supplies. The system can also continue to detect fire and perform emergency operations, even if one part of the system loses communication with another.

The FireFinder system is available in two models, the XLS and the XLSV. The XLSV offers all the advanced features of the XLS, plus an Integrated Digital Emergency Voice Evacuation System. For details on the XLS, see page 3. For details on the voice evacuation features of the XLSV, see page 4.

* Typical

FireFinder XLS



A simple sequence of screens tells the whole story.

Step 1, Alarm Event Screen: When an alarm is detected, this screen displays the type of alarm (Smoke, Manual, Heat, Waterflow, etc.), location (customized message) and time of event.



Step 2, Event Details Screen: Press the lighted "More Info" button to view specifics on alarm location (200+ characters of text description), available fire equipment in the area (presented in the form of standard NFPA 170 fire safety symbols), hazards, and occupants typically in that area of the building.



Step 3, Event Map Screen: Press the "Map Button" to view a simple building floor plan that shows fire or building personnel their proximity to the alarm event.



Building Technologies

Siemens Building Technologies, Inc.

8 Fernwood Road, Florham Park, NJ 07932
Phone: 973.593.2600 • Fax: 973.593.6665

Siemens Building Technologies, LTD

2 Kenview Boulevard, Brampton, Ontario L6T 5E4 Canada
Phone: 905.799.9937 • Fax: 905.799.9858

sbt.siemens.com/fis